

## “A” Frame Loader M-32-F

The “A”-frame is one of the more popular loading arm configurations. It provides good flexibility, long reach, and is convenient and easy to use. It adjusts for any changes in the elevation or tilting of the vehicle during loading or unloading. The arm stores neatly in the upright, near vertical position allowing it to swing around easily for loading from either side of the island.

The “A”-frame’s compact storage envelope also allows these arms to be installed relatively close together, often on risers that are approximately the same height as the vehicle connection. They can also be mounted next to one another on staggered risers to achieve arm crossover for simultaneous loading of multiple compartment trucks.

Commonly used for tank truck bottom loading, “A”-frame arms can also be used in top loading and unloading installations. They are generally equipped with a dry disconnect coupling, union, or other tight-fill fitting.

Inlet flange and seamless piping are suitable for handling liquefied petroleum gases, including propane and butane.

### Benefits

- Easily stored away from vehicles
- For multiple product applications, it can be mounted close to another arm
- Can be safely stored to provide for safe clearance of vehicles
- Crossover can easily be achieved

### Features

- Low riser mounting height
- Available in 2”, 3” and 4”
- Available in steel, stainless steel, aluminum, and specialty alloys
- Choice of flanged, threaded or all welded construction
- LPG service arms (LPG-32-F)- all welded construction
- Welded assemblies in steel and stainless steel with 300 lb. flanges

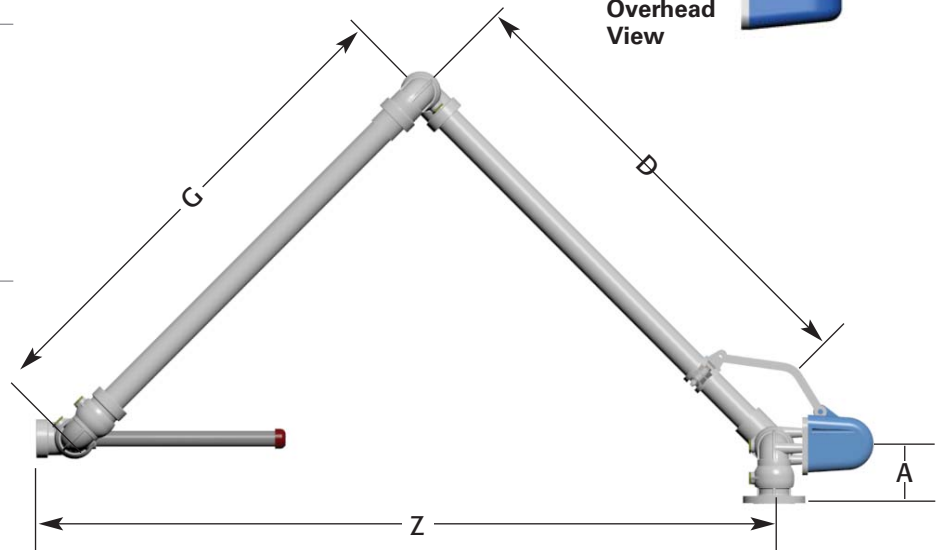
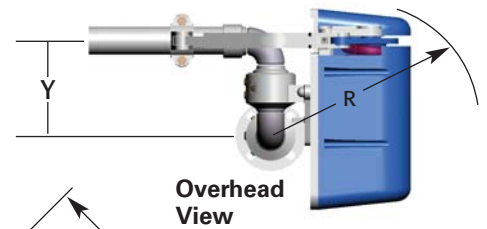

### Dimensions\*

Size	A		D		G		Z		R		Y		
	in.	mm	in.	mm	in.	mm	in.	mm	in.	mm	in.	mm	
2"	51	8-5/8	219	60	1524	60	1524	90	2286	17	432	8-1/8	206
3"	76	10-1/2	267	60	1524	60	1524	90	2286	18-1/2	470	10-3/4	273
4"	102	11-3/4	298	60	1524	60	1524	90	2286	20	508	12-3/4	324

\*Custom dimensions also available.