

DoubleTrac[®]

Easy Installation. Zero Permeation.

Flexible Double Containment Piping Manual-October 2013



OmegaFlex[®]



The Environmental Choice
Next Generation of UL971A
Flexible Double Containment Piping

TABLE OF CONTENTS

INTRODUCTION Page 2

LISTINGS AND APPROVALS..... Page 3

PRESSURE RATINGS Page 3

OPERATING TEMPERATURE Page 3

BEND RADIUS Page 3

ASSEMBLY OF DoubleTrac® BF FITTING Page 4

TIGHTNESS TESTING OF SECONDARY CONTAINMENT PIPING Page 6

PENETRATION BOOT Page 8

ROUTINE MAINTENANCE AND VISUAL INSPECTIONS Page 8

CONTACT INFORMATION Page 8

DoubleTrac® PIPING GUIDE FOR ABOVE GROUND APPLICATIONS..... Page 9

OUTDOOR AND MARINA INSTALLATIONS Page 10

DoubleTrac® LIMITED WARRANTY INSTALLATION FORM Page 11

DoubleTrac® PRE-INSTALLATION CHECK LIST Page 12

DoubleTrac® LIMITED WARRANTY ABOVE GROUND AND MARINA Page 13

DoubleTrac® LIMITED WARRANTY BELOW GROUND AND MARINA Page 14



DoubleTrac Underground, Above Ground and Marina Piping System

SECTION 1.0 – INTRODUCTION

▲ CAUTION

This manual provides the installer with general instructions for the design and installation of underground, above ground and marina fuel piping systems using DoubleTrac® flexible petroleum piping system with built-in secondary containment.

This information deals primarily with underground, above ground and marina fuel piping. Other components of the piping system have their own individual installation instructions provided by the equipment manufacturer. The installation instructions provided by all component manufacturers must be followed for the underground, above ground and marina petroleum piping system to operate safely as designed.

The OmegaFlex DoubleTrac® flexible piping system must only be installed or serviced by a qualified installer who has been trained through the Underground, Above Ground and Marina Petroleum Piping Systems Installation Training Program. The use of non-trained personnel or any deviations from these written procedures could result in damage or leakage of the system and void the product warranty. Contact OmegaFlex Customer Service for more information at 800-355-1039.

These instructions must be used in conjunction with federal and state regulations for underground, above ground and marina bulk petroleum storage and piping.

All underground, above ground and marina fuel piping systems must be installed in accordance with recognized engineering practices. The industry standards for the installation of underground, above ground and marina tanks including piping systems are PEI RP100, RP200 and RP1000.

At the completion of work this installation manual must be given to the site operator or owner.

▲ CAUTION

If the DoubleTrac® system is improperly installed, the contents of the piping may leak and possibly cause personal injury or damage to the environment. The instructions in this manual and applicable local codes must be strictly followed.



Important Information Follow All Instructions

SECTION 2.0 - LISTINGS and APPROVALS

OmegaFlex DoubleTrac® flexible piping system has both a primary and secondary containment jacket and is listed with UL 971A/ULC S667-11 under file number MH 45578, titled: METALLIC UNDERGROUND FUEL PIPE. DoubleTrac® flexible piping may be used in the following applications.

- Pressure System Supply Piping
- Suction System Supply Piping
- Tank Vent Piping
- Stage II Vapor Recovery Piping
- Remote Fill Lines

Although DoubleTrac is listed with UL/ULC; these are specific for metallic underground fuel piping. As of the revision date of this Design and Installation Guide, UL/ULC does not offer a listing for double containment piping for aboveground or marina fuel systems.

DoubleTrac is designed for above ground and marina installations as the Nylon 12 is extremely durable and is UV stabilized to be exposed to the elements. When requested, OmegaFlex can supply documentation supporting these installations.

SECTION 3.0 - PRESSURE RATINGS

DoubleTrac® flexible piping and fittings have a minimum five to one safety factor from the maximum rated operating pressure for the primary and secondary pipes. The product media should not exceed the maximum operating pressures indicated for each pipe size shown in Table 1.

SECTION 4.0—OPERATING TEMPERATURE

All DoubleTrac® products are rated for -40°F to +120°F.

SECTION 5.0—BEND RADIUS

DoubleTrac® flexible piping should never be bent at a radius smaller than the designed bend radius shown in Table 2.

Table 2

Pipe Size	Minimum Bend Radius
1"	12"
1-1/2"	24"
2"	32"

SECTION 6.0 - INSPECTION, HANDLING and STORAGE

Inspect all piping, fittings and components when they arrive at the job site. Any piping that has been cut, crushed, or otherwise subjected to physical damage during transportation or storage shall be discarded and never used. The piping and fittings shall be handled in such a manner that will not cause any unnecessary damage. Keep all components in the original packaging until ready for use. Inspect fittings prior to installation.

⚠ CAUTION

The end of the piping must be protected at all times. Extra caps are provided with each shipment.

Table 1

Pipe Size	O.D. Nom	Weight	Primary Max Operating Pressure	Secondary Max Operating Pressure	Max Vacuum Rating
1"	1.55	0.75 lbs/ft	125 psig	50 psig	29" Hg
1-1/2"	2.30	1.50 lbs/ft	100 psig	50 psig	29" Hg
2"	2.93	2.00 lbs/ft	75 psig	50 psig	29" Hg

SECTION 7.0 - ASSEMBLY OF DoubleTrac® BF FITTING

Tools required for Assembly

- Utility Knife with sharp blade
- Appropriate size allen wrench
- Tubing Cutter

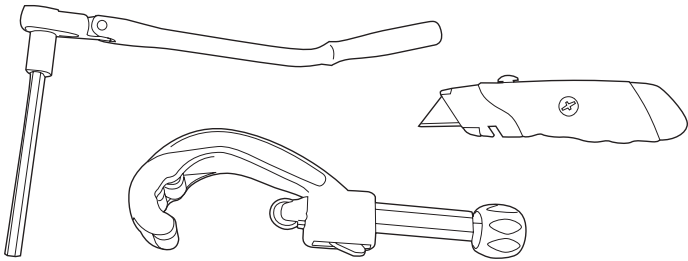

1. Components

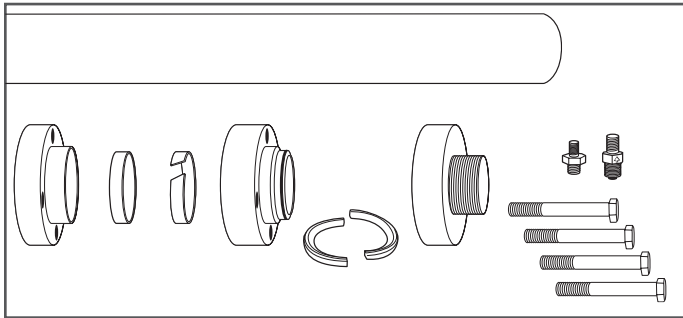

2. To determine the rough jacket strip length measure back 3" from the end.

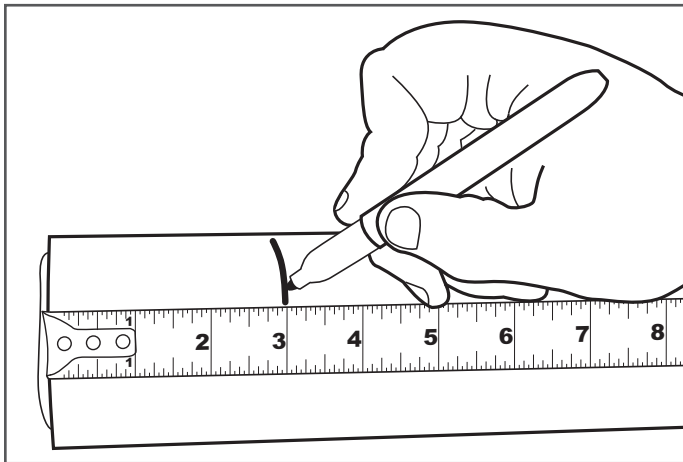

3. Using the tubing cutter, score the black sleeve approximately half of the way through all around the sleeve circumference. Use extreme caution not to cut or score the stainless corrugated pipe. Typically, no more than two turns on the cutter is sufficient.

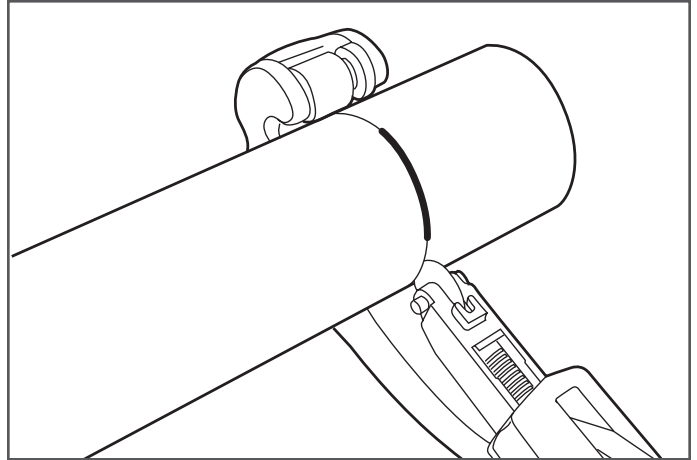

4. Finish cutting through the outer jacket down to the stainless corrugated pipe using a sharp utility knife.

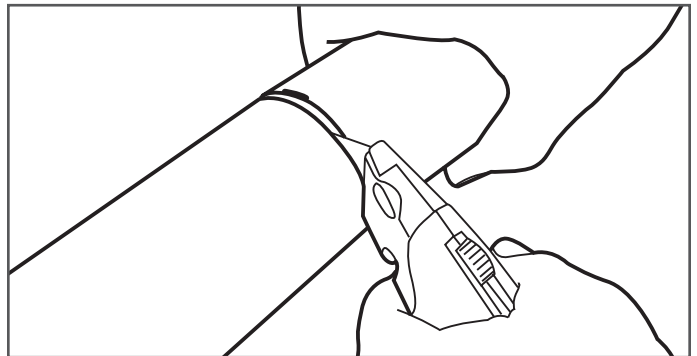

5. Carefully cut jacket with a utility knife for ease of removal. Do not score DoubleTrac® piping.

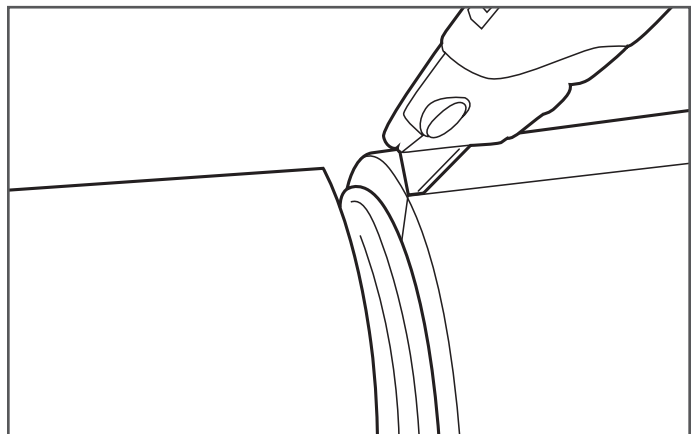

6. Remove portion of jacket

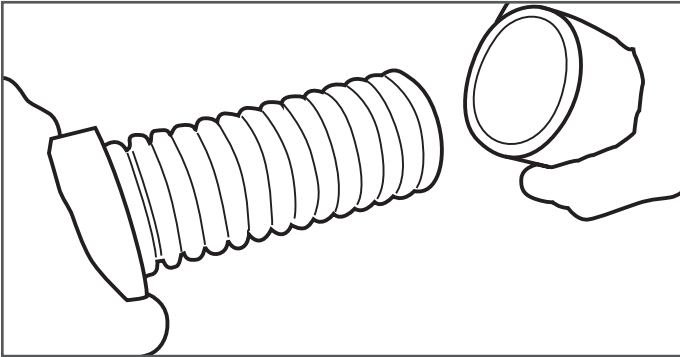

▲ CAUTION

NOTE: Inspect the stainless steel pipe for scoring from the tubing cutter. If the stainless steel pipe is damaged, remove the damaged portion and repeat this procedure.

▲ CAUTION

Finishing the cut by bending or twisting may cause an improper seat.

▲ CAUTION

NOTE: When making the final cut, do not cut DoubleTrac® with a reciprocating saw or hack saw.

7. Preparing piping for final cut. Slide middle section of fitting into the DoubleTrac pipe until it bottoms out.

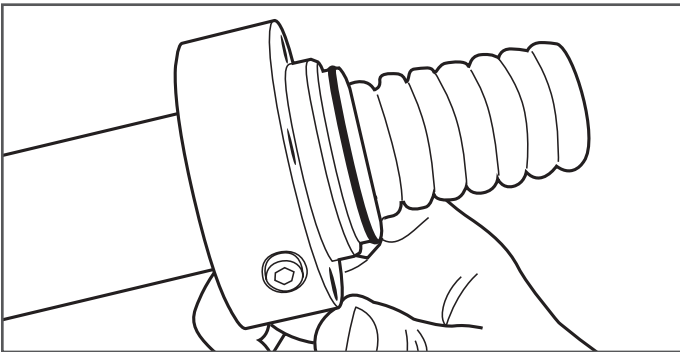

8. Marking the piping for final cut. Once the middle section of the fitting has bottomed out on piping, place a mark on top of the first two corrugations that are past the middle section of the fitting.

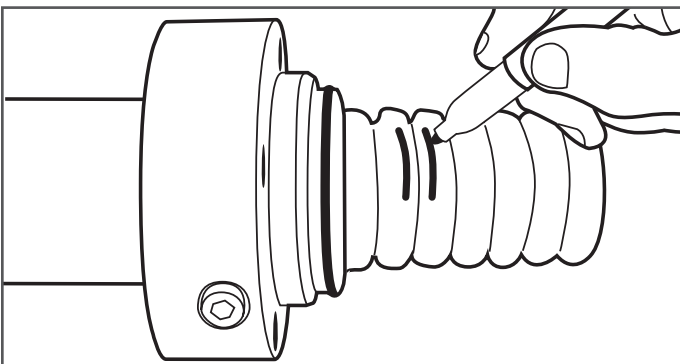

9. Cut through the corrugated piping using a tubing cutter with a sharp wheel. Cut must be centered in the valley between the two marked corrugations. Use full circular strokes in one direction and tighten roller pressure slightly after each revolution. DO NOT over tighten roller which may flatten tube.

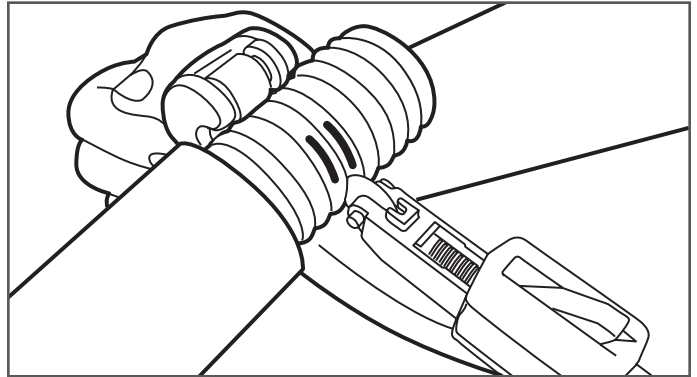

10. Slide the back and middle section of the fitting onto the pipe and insert the split rings into the valley of the first corrugation closest to middle section of the fitting.

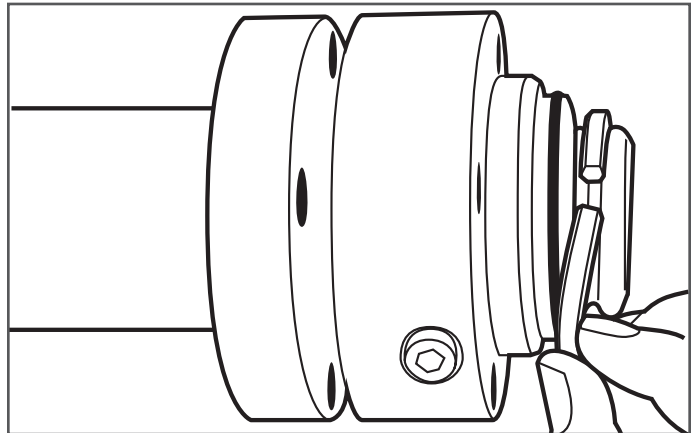

Slide the back and middle section of the fitting up until the split rings are covered by fitting.

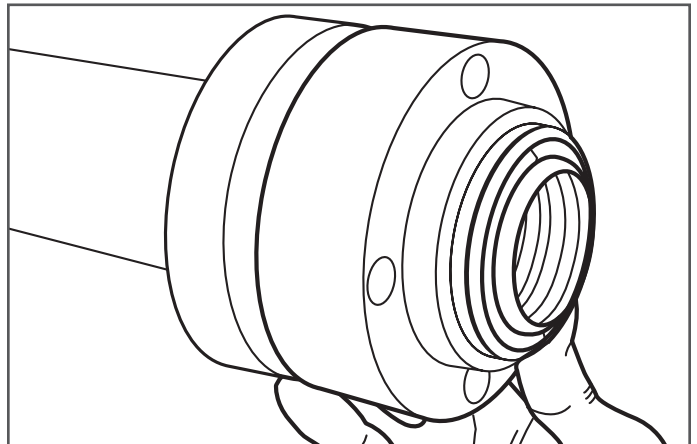

Important Information Follow All Instructions

11. Thread the NPT front section into the existing piping (elbow, tee, valve etc). Slide the middle and back sections up to the front section and hold in place.

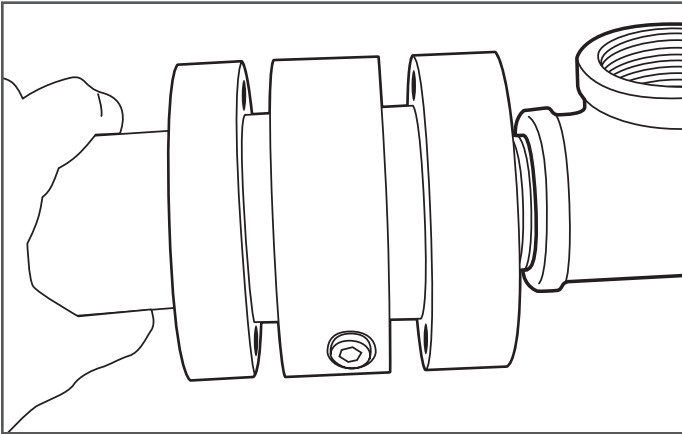

⚠ CAUTION

NOTE: Do not use any pipe dope or thread sealants on the self-flaring connection. This connection is a metal to metal seat and will not seal properly if pipe dope or thread sealants are used. Sealants are to be used on the NPT Connector to the equipment only.

Insert cap screws into the back section of the fitting and tighten the screws in an alternating pattern to ensure an even compression of the fitting.

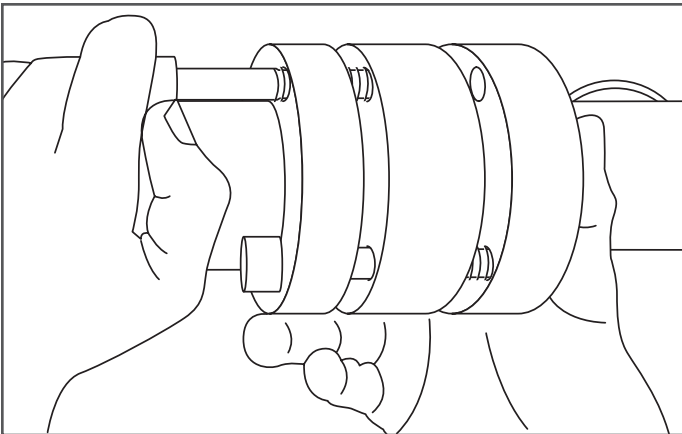

12. Tighten all cap screws in an alternating pattern.

Table 2

DoubleTrac® Pipe Size Recommended Torque Values

DoubleTrac® Pipe Size	Torque Settings
1"	30 FT-LBS
1-1/2" & 2"	50 FT-LBS

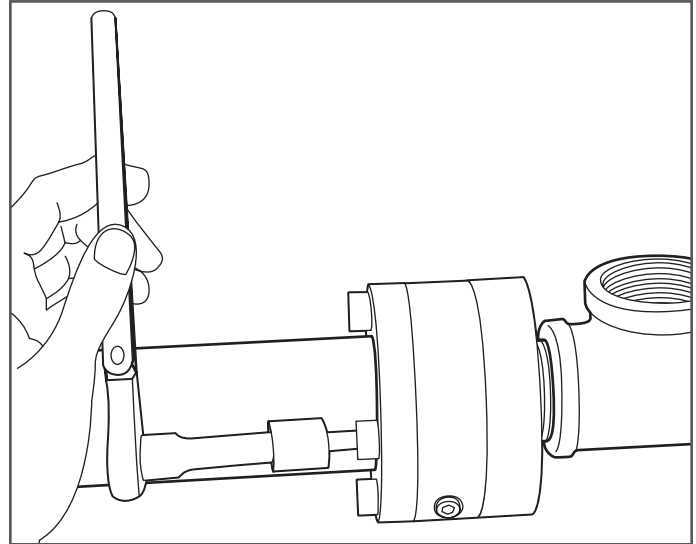

SECTION 8.0 - TIGHTNESS TESTING OF SECONDARY CONTAINMENT PIPING

For tightness testing of DoubleTrac flexible piping, the secondary piping (Interstitial space) is pressurized with air up to 50 psig for a minimum of 30 minutes with no loss of pressure allowed. All joints should be wetted with a non-corrosive leak test solution and inspected for bubbles. The use of “soap” solutions is not permitted with stainless steel piping due to the corrosion potential of chlorinated compounds.

The installer shall deliver a copy of the test results to the site owner or operator, who shall keep a copy of all final test results.

NOTE: When testing the secondary, the primary is also being tested.

⚠ CAUTION

NOTE: When performing a tightness test, the piping must be completely isolated from the rest of the system.

Important Information Follow All Instructions

SECTION 9.0 - TIGHTNESS TESTING OF PRIMARY PIPING

Before the piping system is backfilled, it must be isolated from the tanks and subjected to a pipe tightness test on the primary and secondary piping.

For tightness testing of DoubleTrac® flexible piping, the primary piping is pressurized with air to a level of 1.5 times the maximum operating pressure of the system. Maintain this pressure for a minimum of one hour, making sure there is no drop in pressure.

SECTION 10.0—INSTALLATION OF CHECK VALVES

Once all testing has been completed, remove body of Schrader valve and thread on check valve to Schrader valve. The arrow on the check valve should point away from the fitting.

▲ CAUTION

NOTE: If check valves are not installed, then the plug which originally came with the fitting must be installed. Prior to releasing for service, either a plug or check valve must be installed. Failure to do so voids all warranty.

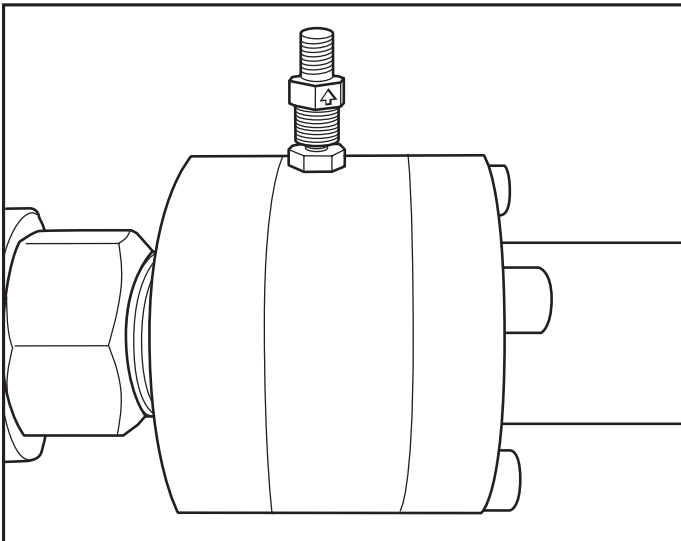

SECTION 11.0—PIPE BURIAL, TRENCHING AND BACKFILL REQUIREMENTS

Provide a trench width equal to the pipe diameter plus six inches on each side. Separate multiple lines by at least 4 inches. The distance between any piping and the trench excavation walls must be at least 6 inches. For example, an installation of three 2" diameter pipes, the trench would be 26" wide and a minimum of 26" deep.

Whenever possible, product lines should be run in a single trench between the tank area and pump dispenser island area. Vent lines between the tank and the structure to which the aboveground vent lines are attached should also be installed in a single trench. Where more than one trench is required, piping should not cross over each other or cross over underground, above ground and marina tanks.

The trench bottom must be sloped uniformly from the dispensers back to the tanks or sumps at a minimum slope of 1/8 inch per foot and be free of any sharp or protruding hard objects. The trench bottom must be graded with a minimum of six inches of backfill such as washed sand, or pea gravel.

For backfilling, provide a minimum level of clean backfill between the top of the pipe and the surface as provided in Table 6.

Table 6

Surface Pavement	Min. Depth of Pavement	Min. Level of Clean Backfill
Unpaved	N/A	18"
Asphalt	2"	8"
Reinforced Concrete	4"	4"

▲ CAUTION

Native back fill materials should never be used.

SECTION 12.0 – PENETRATION BOOT

OmegaFlex recommends the boots shown in tables 7 and 8 to properly mate up with DoubleTrac piping. These boots have been evaluated to proper sizing, although other boots and manufacturers might also be compatible. All boots must meet local, state, and federal regulations for bulk petroleum storage and piping.

Table 7 - DoubleTrac Pipe Size-Recommended Fittings for Single Wall Sumps

DoubleTrac Pipe Size	O.D. Nom	Bravo Part No.	Diversified Part No.	Icon Part No.
1"	1.55	UGF-10-OFLX	B 3.5-1.6	RFSF1.6
1-1/2"	2.30	UGF-15-OFLX	B 3.5-2.4	RFMF2.25
2"	2.93	UGF-20-OFLX	B 5-3.0	RFMF3.0

Table 8 - DoubleTrac Pipe Size - Recommended Fittings for Double Wall Sumps

DoubleTrac Pipe Size	O.D. Nom	S.A. Bravo Part No.	Diversified Products Part No.
1"	1.55	UGF-10-OFLX-D	U8M-1.6
1-1/2"	2.30	UGF-15-OFLX-D	U8M-2.4
2"	2.93	UGF-20-OFLX-D	U8M-3.0

SECTION 13.0 – ROUTINE MAINTENANCE AND VISUAL INSPECTIONS - PROBLEMS

It is recommended that a visual inspection of the inside of all containment sumps be completed at least once per month. Fuel leaks collected in containment sumps must be reported immediately and investigated by the site owner. If leakage or damage to the piping system is suspected, OmegaFlex must be notified immediately.

All sumps must be kept free of fuel, water and debris. When changing fuel filters at the dispenser, make sure any spilled product is cleaned out of the bottom of the dispenser sump to prevent possible fire hazard.

SECTION 14.0 – OmegaFlex Inc. Contact Information

OmegaFlex Inc. can be contacted if there are any questions concerning the installation, maintenance or repair of DoubleTrac® flexible piping system. Please contact OmegaFlex customer service and 1-800-355-1035 or on the web at www.omegaflex.com or www.doubletrac.net.

▲ CAUTION

Ignoring or disabling leak detection alarms can lead to further damage and possible failure of the system.

Failure to remove fuel and liquids from the containment sumps may compromise the performance and integrity of the sump and its associated fittings (entrance boots) and seals over prolonged periods of time.

APPENDIX A

DoubleTrac® Piping Guide for Above Ground Applications

Overview

DoubleTrac’s® innovative double wall design includes a primary interior layer of zero-permeation, highly corrosion resistant corrugated stainless steel with an outer EFEP barrier layer bonded to a Nylon 12 protective layer. The unmatched strength of stainless steel combined with the superior chemical resistance of EFEP in the secondary barrier layer provide a highly durable design utilizing proven materials in the industry. The interstitial space provides continuous monitoring for leak detection—making DoubleTrac® the industry’s most effective Zero Permeation piping solution. This piping is suitable for use in marinas, harbors, fuel terminals, fuel oil lines, and emergency generator feed and return lines.

Operating Parameters

SIZE	1"	1.5"	2"
MAX WORKING PRESSURE (psig)	125 Primary 50 Secondary	100 Primary 50 Secondary	75 Primary 50 Secondary
MINIMUM BEND RADIUS (inches)	12	24	32
WEIGHT (lbs / ft)	0.75	1.50	2.00
OPERATING TEMPERATURE (deg F)	-40 / 120		

Application Basics

All installations must be performed by a trained operator. Typically each installation is unique and requires some level of review; however there are some general guidelines that are applicable to all installations. Inspect all piping, fittings and components when they arrive at the job site. Any piping that has been cut, crushed, or otherwise subjected to physical damage during transportation or storage shall be discarded and never used. The piping and fittings shall be handled in such a manner that will not cause any unnecessary damage. Keep all components in the original packaging until ready for use. Inspect fittings prior to installation.

Maintaining a continuous slope from the dispenser to the tank is oftentimes not possible; specifically regarding marina refueling systems. Maintain a uniform slope for as much of the piping as feasible, whether the slope is toward the tank or toward the dispenser. To the extent practical, minimize the number of times the direction of the piping slope changes.

In particular, marinas have some specific requirements. Additionally, refer to the DoubleTrac® design and installation guide (DBT-001) for proper fitting assembly technique.

Outdoor Installations

When installed outdoors, the DoubleTrac piping must be adequately protected from puncture, shear, crush or other physical damage threats, including possible damage from:

- vehicular or pedestrian traffic, corrosion,
- twisting, bending, kinking, chafing, or other excessive or prolonged movement of the piping,
- construction and excavation,

When installed along the side of a structure in an exposed condition, the DoubleTrac piping shall be installed in a location which will not subject the piping to mechanical damage. NOTE: For support and protection, OmegaFlex recommends that outside runs along the side of a building be clipped securely to the wall or other structural component every six feet. Typical supports are Unistrut conduit hangers, “U” bolts, PVC pipe couplers, or Hosebuns.

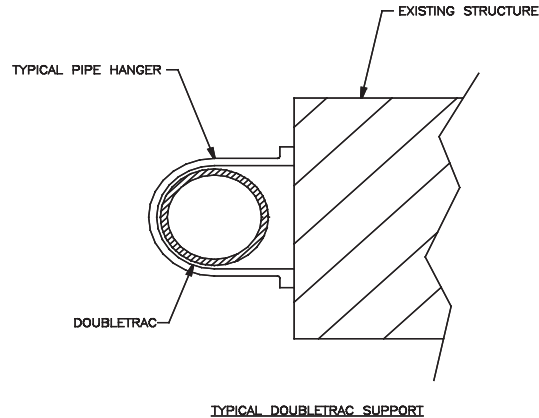

Marina Installations

Fixed Dock

When installing DoubleTrac® on a fixed dock, the piping may be run along the side or underneath it. In either case, the routing must be such that it cannot be damaged, crush, kinked during normal use of the dock. The piping must be supported evenly along the entire run; supports are required every six feet. Typical supports are Unistrut conduit hangers, “U” bolts, PVC pipe couplers, or Hosebuns.

Floating Dock

DoubleTrac® should not be installed on the walkway from the shore to the dock. The constant flexing due to tide changes will cause fatigue and possible failure of the primary piping. The dock to shore connection should be an approved flexible connector. DoubleTrac® piping can be installed along the length of the floating dock portion. The routing must be such that it cannot be damaged, crush, kinked during normal use of the dock. The piping must be supported evenly along the entire run; supports are required every six feet. Typical supports are Unistrut conduit hangers, “U” bolts, PVC pipe couplers, or Hosebuns.

▲ CAUTION

DoubleTrac® piping is not an approved flex connector. Please contact OmegaFlex Engineering Department for flexible double contained dock connectors at 1-800-355-1039.

Routine Maintenance and Visual Inspections

It is recommended that a visual inspection of all components as well as the inside of all containment sumps be completed at least once per month. Typical monthly inspections include, but are not limited to:

- visual inspection of piping: no visible damage to the outer jacket such as cracks, crushing, kinking, or puncture
- visual inspection of all mounting hardware: all hardware must be intact and securely mounted in the original location
- visual inspection of DoubleTrac fittings: no visible damage to fittings, no sign of leakage, any vent/test port fittings or bypass hoses should show no sign of crushing, kinking, or puncture.

Fuel leaks collected in containment sumps must be reported immediately and investigated by the site owner. If leakage or damage to the piping system is observed or suspected, OmegaFlex must be notified immediately. All sumps must be kept free of fuel, water and debris. When changing fuel filters at the dispenser, make sure any spilled product is cleaned out of the bottom of the dispenser sump to prevent possible fire hazard.

Contact Information

OmegaFlex Inc. can be contacted if there are any questions concerning the installation, maintenance or repair of DoubleTrac® flexible piping system. Please contact OmegaFlex customer service and 1-800-355-1035 or on the web at www.omegaflex.com or www.doubletrac.net.

LIMITED WARRANTY- Installation Form

Warranty Disclaimer: The DoubleTrac Limited Warranty is only valid if this form is received by the DoubleTrac Customer Service Team within 30 days after installation is complete.

Contractor

Installation Site

Name _____ Address _____ Email _____ Phone _____ Fax _____ Distributor _____
Name _____ Address _____ Installation Date _____ Completion Date _____
Installer's State Certification No. _____ Installer's Training Cert No.: _____

Piping

1. What size pipe was used? (Circle one) 1" 1.5" 2"
2. Was any other underground piping used other than DoubleTrac? (Circle one) Yes No
If so, what kind?

3. What types of fuels are to be stored? (Circle all that apply)
Gasoline Gasohol Diesel Ethanol Methanol Fuel Oil Bio-diesel
Other _____

Please circle yes or no to the following:

4. Was the site contaminated before installation? Yes No
If yes: (a) Was the site fully remediated? Yes No
(b) Did the site receive clearance from government authorities? Yes No
(c) What is the name of the environmental contractor? _____
5. Were all piping and fittings inspected for damage before and after installation? Yes No
6. Was approved backfill material used? Yes No
7. Was the Installation Manual followed? Yes No
8. Was any direct bury pipe crossed over? Yes No If so were crossover supports used? Yes No
9. Were all Self-Flaring Fittings tightened to spec? Yes No
10. Was the DoubleTrac Primary Pipe pressure tested? Yes No
11. Was the DoubleTrac Interstitial Space pressure tested? Yes No
12. Was Chase Pipe used? Yes No
13. Was the Secondary Jacket left open to atmosphere after testing? Yes No

Pipe Entry Points (please provide)

Name of Boot Manufacturer _____
All Boot part numbers _____
Circle yes or no: Was the exact size hole drilled for each entry boot? Yes No
Were all band clamps secured? Yes No Were the entry boot nuts properly tightened? Yes No

Dispenser Sumps (please provide)

Name of Dispenser Sump Manufacturer _____
All Dispenser Sump part numbers _____
Circle yes or no: Were sumps inspected for damage before and after installation? Yes No
Were the instructions followed? Yes No

Tank Sumps (please provide)

Name of Tank Sump Manufacturer _____
All Tank Sump part numbers _____
Contractor Signature _____ Date _____



Manufacturer of Flexible Metal Hose and Gas Piping Products

DoubleTrac® Pre-Installation Check List

The following items should be completed before OmegaFlex® personnel arrive on site for training:

- Two week minimum lead time for OmegaFlex personnel to be on site
- All existing product removed
- All ancillary equipment set i.e. tanks & sumps
- All ground work completed i.e. trenches dug or supports hung
- DoubleTrac pipe and fittings are on site

Please fill out the following information:

Contact for DoubleTrac Installation _____

Company Name _____

Telephone _____

Project Name _____

Project Type (*circle*) UST AST Retail Marina Emergency generator/boiler

Requested installation Date _____

Sign _____

Date _____

Please fax form to **610.524.6484**

LIMITED WARRANTY- Above Ground and Marina

PRODUCT	LENGTH OF WARRANTY
DoubleTrac flexible petroleum pipe & fittings	15 years

Omega Flex, Inc. warrants to the purchaser of the DoubleTrac® flexible piping system that the products listed above (the “Product”) when installed in above ground applications or on fixed or floating docks will be free from defects in material or workmanship for period stated above, as measured from the date of shipment from DoubleTrac. This excludes DoubleTrac dock connectors which are covered under a separate warranty.

If upon examination, the Product is shown to have a defect in material or workmanship during the warranty period, DoubleTrac will, at its option, either repair or replace that part of the Product which is shown to be defective, or issue a credit for the amount of the defective product that may be applied to future orders of the Product.

This limited warranty does not apply:

- If the Product has been subjected to misuse or neglect, has been accidentally or intentionally damaged, or has been altered or modified in any way.
- If the Product has been repaired by anyone who is not a DoubleTrac authorized service representative.
- If the Product has not been installed in accordance with the DoubleTrac installation guidelines.
- If the Product has been installed with unauthorized third party components, except those components that are recommended for use with DoubleTrac in the DoubleTrac installation guide.
- To any costs or expenses incurred during investigation, removal or reinstallation of the defective Product, including without limitation any costs or expenses for clean-up, downtime, or lost profits.
- To any damage or impairment of the Product caused by any casualty, including without limitation fires, storms, floods, earthquakes, or acts of God.
- To any workmanship of the installer of the Product.

This limited warranty is conditional upon:

- Receipt of a written warranty claim during the applicable warranty period.
- Installation of the Product by an individual who has received factory authorized training on the installation and proper use of DoubleTrac.
- All site and warranty registration forms are completed and received by DoubleTrac within 30 days of installation.
- All piping and connections are installed with an approved leak detection device in each tank and dispenser sump.
- A sump inspection log or EPA checklist is maintained and provided to DoubleTrac on request.
- DoubleTrac receives notice of warranty claim within 24 hours of any known or suspected failure of the Product.

Product can only be returned with prior written approval from DoubleTrac. All returns must be freight prepaid. Manufacturer will inspect the alleged defective part, and provide the customer with the results of that inspection whether or not in the reasonable opinion of DoubleTrac, that there exists a defect in material or workmanship. Repair or replacement of any part under this Limited Warranty shall not extend the duration of the warranty with respect to such repaired or replaced part beyond the stated warranty period.

IMPORTANT

This limited warranty is in lieu of all other warranties, either express or implied, and all such other warranties, including without limitation implied warranties of merchantability or fitness for a particular purpose, are hereby disclaimed and excluded from this limited warranty.

LIMITATION OF LIABILITY

In no event will DoubleTrac be liable in any way for (a) any consequential, special, or incidental damages of any nature whatsoever, or (b) any amounts in excess of the selling price of the Product or any parts thereof found to be defective.

LIMITED WARRANTY- Below Ground

PRODUCT	LENGTH OF WARRANTY
DoubleTrac flexible petroleum pipe & fittings	30 years

Omega Flex, Inc. warrants to the purchaser of the DoubleTrac® flexible piping system that the products listed above (the “Product”) when installed in below ground applications will be free from defects in material or workmanship for period stated above, as measured from the date of shipment from DoubleTrac.

If upon examination, the Product is shown to have a defect in material or workmanship during the warranty period, DoubleTrac will, at its option, either repair or replace that part of the Product which is shown to be defective, or issue a credit for the amount of the defective product that may be applied to future orders of the Product.

This limited warranty does not apply:

- If the Product has been subjected to misuse or neglect, has been accidentally or intentionally damaged, or has been altered or modified in any way.
- If the Product has been repaired by anyone who is not a DoubleTrac authorized service representative.
- If the Product has not been installed in accordance with the DoubleTrac installation guidelines.
- If the Product has been installed with unauthorized third party components, except those components that are recommended for use with DoubleTrac in the DoubleTrac installation guide.
- To any costs or expenses incurred during investigation, removal or reinstallation of the defective Product, including without limitation any costs or expenses for clean-up, downtime, or lost profits.
- To any damage or impairment of the Product caused by any casualty, including without limitation fires, storms, floods, earthquakes, or acts of God.
- To any workmanship of the installer of the Product.

This limited warranty is conditional upon:

- Receipt of a written warranty claim during the applicable warranty period.
- Installment of the Product by an individual who has received factory authorized training on the installation and proper use of DoubleTrac.
- All site and warranty registration forms are completed and received by DoubleTrac within 30 days of installation.
- All piping and connections are installed with an approved leak detection device in each tank and dispenser sump.
- A sump inspection log or EPA checklist is maintained and provided to DoubleTrac on request.
- DoubleTrac receives notice of warranty claim within 24 hours of any known or suspected failure of the Product.

Product can only be returned with prior written approval from DoubleTrac. All returns must be freight prepaid. Manufacturer will inspect the alleged defective part, and provide the customer with the results of that inspection whether or not in the reasonable opinion of DoubleTrac, that there exists a defect in material or workmanship. Repair or replacement of any part under this Limited Warranty shall not extend the duration of the warranty with respect to such repaired or replaced part beyond the stated warranty period.

IMPORTANT

This limited warranty is in lieu of all other warranties, either express or implied, and all such other warranties, including without limitation implied warranties of merchantability or fitness for a particular purpose, are hereby disclaimed and excluded from this limited warranty.

LIMITATION OF LIABILITY

In no event will DoubleTrac be liable in any way for (a) any consequential, special, or incidental damages of any nature whatsoever, or (b) any amounts in excess of the selling price of the Product or any parts thereof found to be defective.



Omega Flex, Inc.
 451 Creamery Way, Exton, PA 19341-2509
 800-355-1039 • Fax 610-524-6484
www.omegaflex.com
 ISO 9001 Registered Company

Corporate Offices
 13 Court Street, Suite 1001, Middletown, CT 06457
 860-704-6820 • Fax 860-704-6830