

# Maintenance Manual



## Automated Fuel Maintenance System

FTI-10A & FTI-20A



FUEL TECHNOLOGIES INTERNATIONAL

Replacement Manuals Available on Website: [www.fueltechnologiesinternational.com](http://www.fueltechnologiesinternational.com)

03/01/2011 Rev D—Fuel Technologies—FTI-10A & FTI-20A

# Maintenance Section

## FTI - Fuel Maintenance Systems

### Contents

General Maintenance Note's.....	Page 3
Identifying Parts	
FTI-10A & 20A.....	Page 3
Identifying Maintenance and Replacement Parts	
FTI-10A & 20A.....	Page 4
Gauge Layout.....	Page 5
Changing Filters	
1-Micron / Separator Filter.....	Page 6
Strainer, 10-Micron and 3 Micron Filters.....	Page 7
Draining Water Separator.....	Page 8
Water Sensor Alarm & Cleaning Water Level Sensor.....	Page 9
Replacement Filters List.....	Page 10
Troubleshooting Guide.....	Page 11
Warranty.....	Page 12

## GENERAL MAINTENANCE NOTES

Periodically routine maintenance will need to be performed such as changing filters and draining the water separator. When filters become full, the display will indicate the specific filter that requires changing. (Refer to alarm message descriptions in the Operations Manual) For best performance, it is recommended that you **change the filters at least every six (6) months**. A periodic check of the FTI System gauges will assist you in predicting which filters to have on hand before they become clogged. (See "Gauge Layout" section for a description of gauge operations).

It is always a good idea to have spare filters on hand at all times, especially in the early stages of operation. New fuel and existing fuel can have water and particulate in it. Changing weather conditions can also affect your fuel condition.

**IMPORTANT:** Do not attempt any maintenance operation until the system is turned off. Switch the system to "Manual Mode Off" first, to avoid mishaps or leaking fuel. After maintenance, you may return the system to "Auto Mode."

## IDENTIFYING PARTS

The following diagram points out the major components of the FTI System. The example shown is an FTI-20A model. Although your model or custom unit may vary slightly in location of the parts shown, the diagram is representative of the parts you will need to identify.

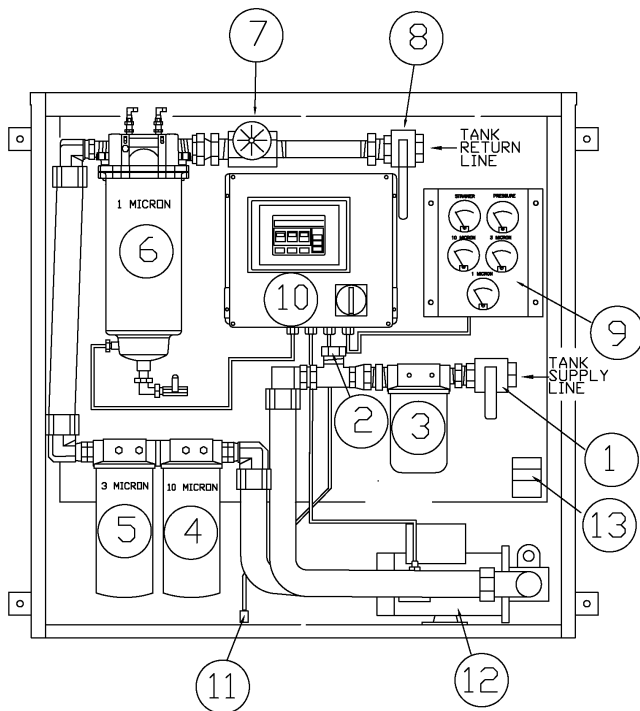

### Models FTI-10A & FTI-20A

1. Supply Line Connection: (Model 10A - 1 1/2" NPT)  
(Model 20A - 2.0 "NPT)
2. Pump Priming Tee
3. Strainer - 100 Mesh, 149 Micron Element
4. 10 Micron Pre Filter, Spin on
5. 3 Micron Pre Filter, Spin on
6. 1 Micron & Water Separator element
7. Site Glass
8. Return Line Connection: (Model 10A-1 1/2" NPT)  
(Model 20A - 1 1/2 "NPT)
9. Switch Gauge Panel
10. Control Panel-230V AC Electrical Connection
11. Leak Detector
12. Pump / Motor
13. Serial No., Model No., FM Approved Tag.

## IDENTIFYING MAINTENANCE & REPLACEMENT PARTS

The following diagram points out the replaceable parts on your FTI system. The example shown below is for the models FTI-10A and FTI-20A. Although your model or custom unit may vary slightly in location of the parts shown, the included diagram is representative of the locations of the parts you will need to service or replace from time to time.

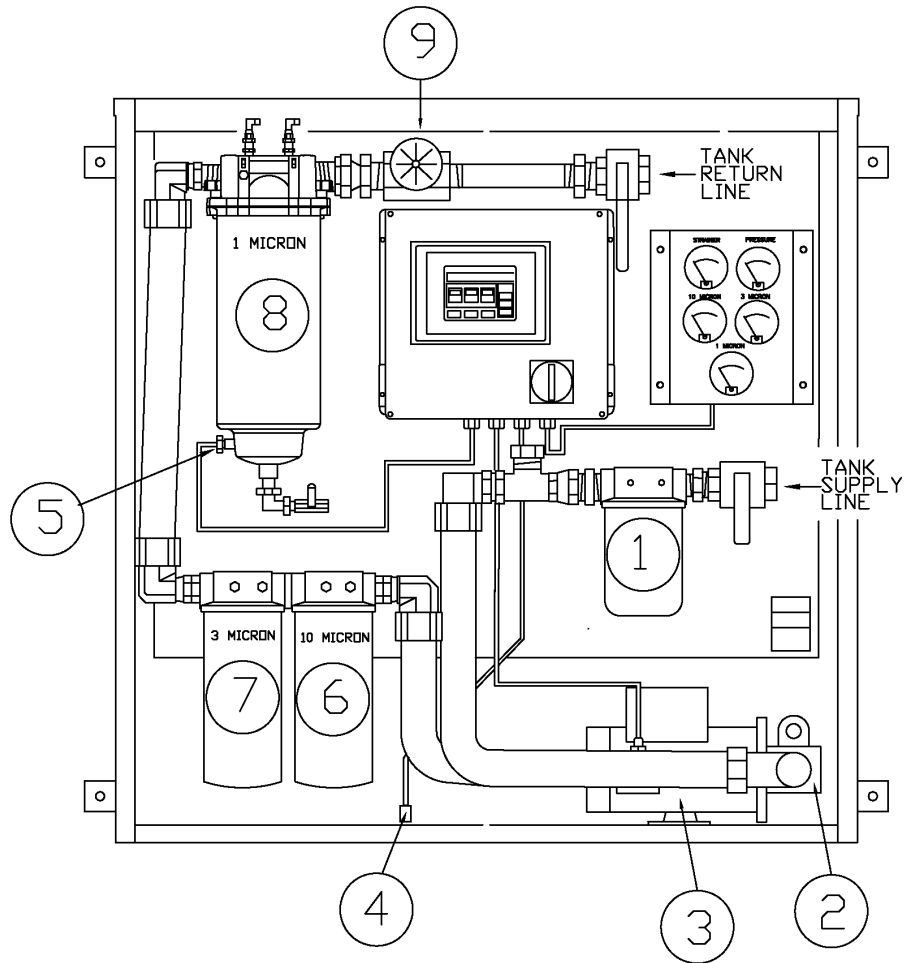

### Maintenance & Replacement Parts

Models Shown: FTI-10A & FTI-20A

1. Strainer – Spin on Element
2. Model 10A- (10 GPM Pump) or Model 20A- (20 GPM Pump)
3. Model 10A- (3/4 HP Motor) or Model 20A- (1 1/2 HP Motor)
4. Leak Detector
5. Water Sensor
6. 10 Micron Pre Filter – Spin on Element
7. 3 Micron Pre Filter – Spin on Element
8. Water Separator and 1 Micron – Replaceable Element
9. Site Glass

## FTI GAUGE LAYOUT

Below is a Diagram of the Switch Gauges on your FTI System.

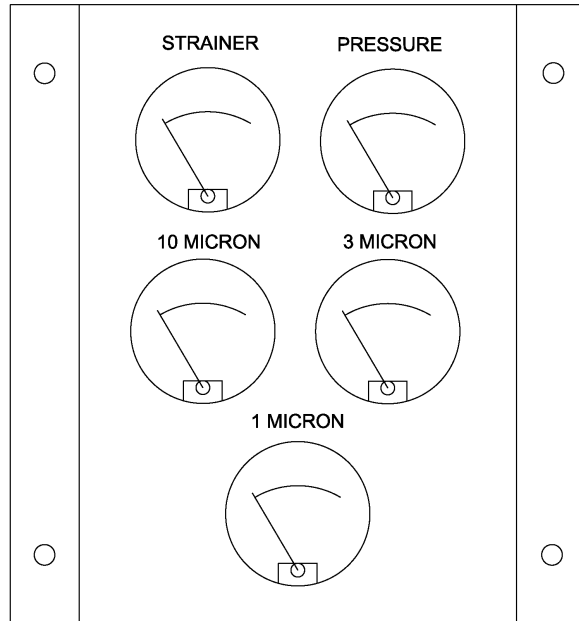

Each switch gauge monitors the filter identified in the above diagram and offers an ongoing visual status of system pressure, vacuum and each filters condition.

**Vacuum (Strainer)** - Monitors 100 mesh strainer. (Alarm Trip & Pump off @ 16-18 In.hg.)

**System Pressure** - Monitors system pressure.

Measurement will vary due to restrictions of filters and length of pipe back to tank.

(45 PSI High Set Point with Alarm & Shut off) (2-3 PSI Low Set Point to Monitor Flow with Alarm & Shut off)

**10 Micron Filter** - Monitors 10-micron filter. (Alarm Trip & Pump off @ 16-18 DP)

**3 Micron Filter** - Monitors 3-micron filter. (Alarm Trip & Pump off @16-18 DP)

**1 Micron Filter** - Monitors 1-micron filter. (Alarm Trip & Pump off @ 16-18 DP)

As the needle nears the contact point of the switch gauges, it indicates the filters are almost full. A check of the gauges can help you determine when to check your supply of filters before they require changing.

When service is required, the unit will turn off, sound an audible alarm, and display the appropriate alarm message description on the controller screen.

Refer to the "Alarm message descriptions" in the Operations Manual for the required maintenance

## Changing the 1 Micron Filter / Water Separator

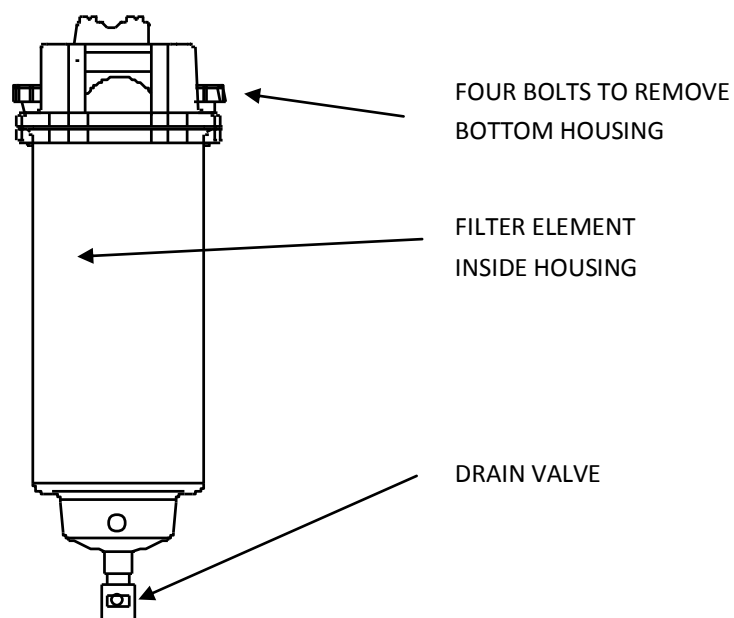

1. Turn off system. Put in manual mode.
2. Close inlet and outlet ball valves
3. Remove ground wire at bottom of filter housing
4. Open air vent valve on the filter head.
5. Drain filter housing at Drain Valve on bottom.
6. Loosen four collar bolts.
7. Rotate & remove housing with filter element.
8. Inspect filter housing, clean if dirty.
9. Remove the head gasket (O-ring).
10. Lubricate and install new gasket.
11. Replace Element with new one.
12. Repeat above steps to close filter housing.
13. Tighten all collar bolts to 100 in lbs.
14. Turn on system and check for leaks.
15. Return system to Auto Mode to run programmed schedule.

## CHANGING STRAINER, 10 MICRON and 3 MICRON FILTERS

Note: If the filter cannot be sufficiently tightened by hand, use a filter wrench (available at most auto supply stores).

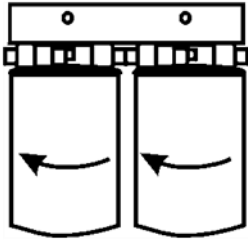

1. To remove filter, put in manual mode.
2. Close inlet and outlet ball valves
3. Drain fuel at left front of filter assembly.  
(This will drain the hose above)
4. Turn filter counter clockwise.

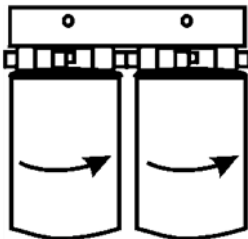

1. Install new gasket supplied with filter.
2. To reinstall new filter, lightly coat seal on filter with fuel. Install by turning clockwise to Apx.  $\frac{1}{2}$  to  $\frac{3}{4}$  turn past point of contact.

Turn system on and check for leaks.

## DRAINING WATER SEPARATOR

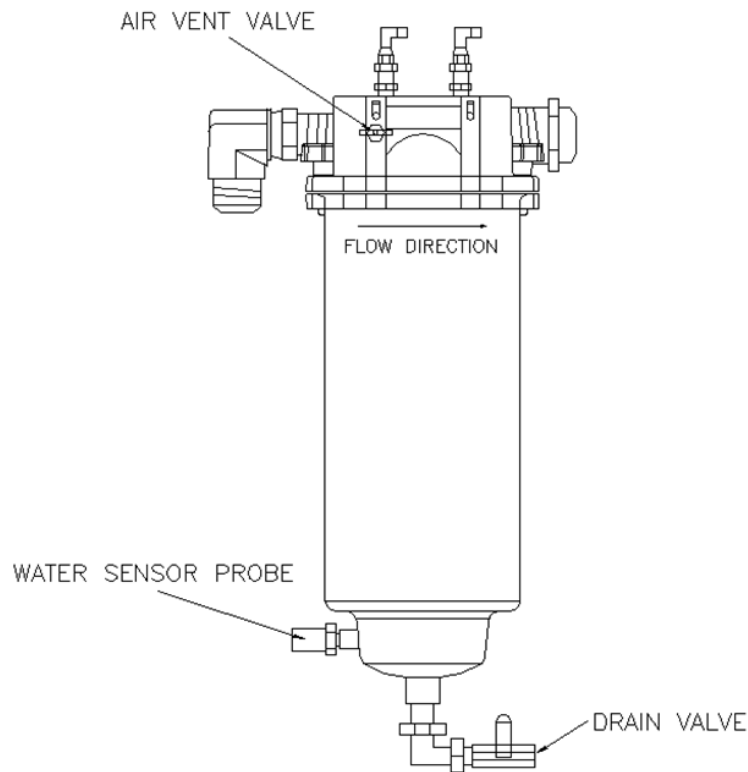

1. Turn off system. Put in manual mode.
2. Close inlet and outlet ball valves.
3. Attach drain hose to bottom drain valve on filter housing.
4. Open top air vent valve on front of filter head.
5. Open ball valve on bottom of filter housing.
6. Drain water
7. Reverse above steps and run system.
8. Check for leaks.
9. Return system to Auto Mode to run programmed schedule.

Note: It is recommended that you periodically drain water separator (even if not yet full) to remove any contaminants collected in bowl, and to reduce the possibility of clogging the petcock and or water sensor.



## WATER SENSOR ALARM

(Alarm Will Not Shut Off After Draining)

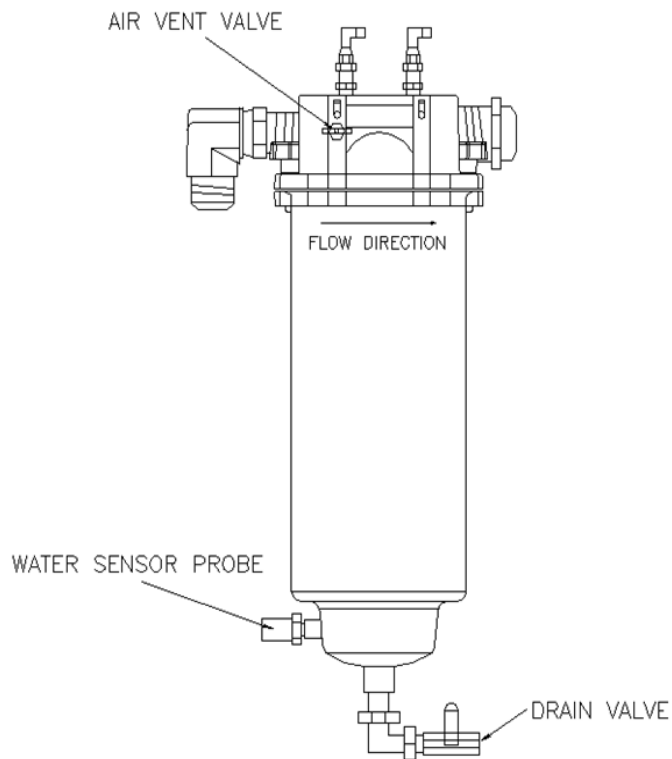

If, after draining water separators, the alarm continues while restarting system, unplug water level sensor cable located near the bottom of filter housing. Restart system and run for several minutes to clean metal elements of sensor. Plug cable in and check system.

If system continues to sound an alarm after above procedure, repeat procedure and run system longer than before.

**Note: If this still fails to clear alarm refer to next Section (cleaning water level sensor)**

## How to Clean Water Level Sensors

Cleaning the water level sensors (located near the bottom of housing) will be required if the contacts become contaminated with dirt or water, and will not allow alarm to be reset or turned off.

1. Drain fuel from the water separator just below water sensor level.
2. Disconnect sensor cable on the side of filter housing.
3. Unscrew water level sensor and remove.
4. Clean metal contacts on sensor with shop towel, then replace.
5. Reconnect cable, start system and check for leaks.

## REPLACEMENT FILTERS LIST

### Five Stages of Filtration:

- Stage 1 • 100 Mesh Stainless Steel - Spin on Element
- Stage 2 • 10-Micron - Particulate Removal – Spin on Element
- Stage 3 • 3 Micron - Particulate Removal – Spin on Element
- Stage 4 • 1-Micron Fine finish - Replaceable Element in Filter Housing
- Stage 5 • Water Separation and removal - Replaceable Element in Filter Housing

To order Replacement Parts, please contact your FTI Representative.

### MODELS - FTI-10A & FTI-20A

- Stage 1 FL-50-100M (100 Mesh Strainer Spin on- 1 ea.) (Model 10A & Model 20A)
- Stage 2 FL-70-10N (10 Micron Spin on - 1 ea.) (Model 10A & Model 20A)
- Stage 3 FL-70-03N (3 Micron Spin on - 1 ea.) (Model 10A & Model 20A)
- Stage 4 & 5 FL-FBO-60327 (1 micron & Water Separation Element-1 ea.) (Model 10A)
- Stage 4 & 5 FL-FBO-60336 (1 micron & Water Separation Element-1 ea.) (Model 20A)

## TROUBLE SHOOTING GUIDE

The following are answers to the most commonly asked questions about the FTI system and potential problems that may occur.

### *System will not operate / Display is not working:*

1. Check power source, circuit breaker in the FTI panel and wiring. If okay;
2. Contact FTI representative.

### *Display reads "Filtering XX tank ON" and pump/motor is not running:*

- Check pump/motor overload Contactor relay (located in control box) reset if needed.
2. Check motor over load button located on motor.(not on all motors)

### *Leaks - Drip around or on bottom of filter:*

Check filter installation and tighten filter if necessary. If this does not stop the leak, check the filter seals. Clean or replace seals as necessary.

### *Water drip:*

Close bottom drain valve on filter housing.

### *Moisture around hose fittings:*

Tighten hose fittings

### *High Pressure Alarm:*

See alarm message descriptions. (Operations Manual page 12, Alarm Message Descriptions)

### *Vibration:*

Check pump-mounting bolts (and all other bolts). Tighten if necessary.

### *Water sensor malfunction still comes on after draining water:*

Follow the procedure using the Water Sensor Alarm Error (Alarm Will Not Shut off after Draining) to flush the sensor elements. (page 8)

### *Low Flow Alarm:*

1. Observe site glass for fuel flow. If fuel flow is present, check pressure switch gauge low setting.
2. Adjust pressure switch gauge low setting.  
(Pressure gauge low set point monitors flow and is set at 2-3 psi)
3. Replace pressure switch gauge

Note: If in doubt or if the problem cannot be resolved, please contact your FTI representative

## LIMITED WARRANTY

FUEL TECHNOLOGIES, INT. LLC (FTI) makes every effort to assure that its products meet high quality and durability standards, and we expressly warrant the original consumer/purchaser of our products that each product is free from defects in materials and workmanship. Our expressed warranty is subject to the following terms and conditions:

1. The term of our warranty is one year from the date of purchase. A warranty claim received by us after one year from the date of purchase will not be honored even if it is claimed that the defect occurred prior to one year from the date of purchase.
2. Our warranty does not cover defects due, directly or indirectly, to misuse, abuse, negligence of others, repairs or alterations done outside of our facilities, or lack of maintenance.
3. Our liability for breach of our express warranty is limited to the repair or replacement of the product, at our cost.
4. We are not liable for general, special, consequential, incidental or contingent damages resulting, directly or indirectly, from the purchase or use of our products.

**WE DISCLAIM ALL WARRANTIES OF MERCHANTABILITY AND FITNESS FOR ANY PURPOSE OF OUR PRODUCTS.**

To make a claim under this warranty, call our Customer Service Representative at 1-805-925-0531. We will ask you to advise us of our Distributor's name and address, the date of purchase, model number, and a detailed explanation of the problem you are experiencing. The Customer Service Representative will arrange for a Field engineer to inspect your system. If our inspection discloses a defect covered by our limited warranty, we will either repair or replace the defective parts of products at our election, and at our cost. If upon inspection, our Engineer determines there is not defect or that the damage to the system resulted from causes not within the scope of our limited warranty, then you must bear the cost of repair or replacement of damaged parts. For service, please contact your local Distributor.

*For your records*

Model No. \_\_\_\_\_ Date of Purchase: \_\_\_\_\_

**Fuel Technologies International LLC**  
Box 6863, Santa Maria, CA 93456  
(805) 925-0531 · FAX (805) 435-1436