

VENTING GUIDE

for aboveground storage tanks

*A Guide Used to Assist in Equipment Selection
for Aboveground Storage Tanks*

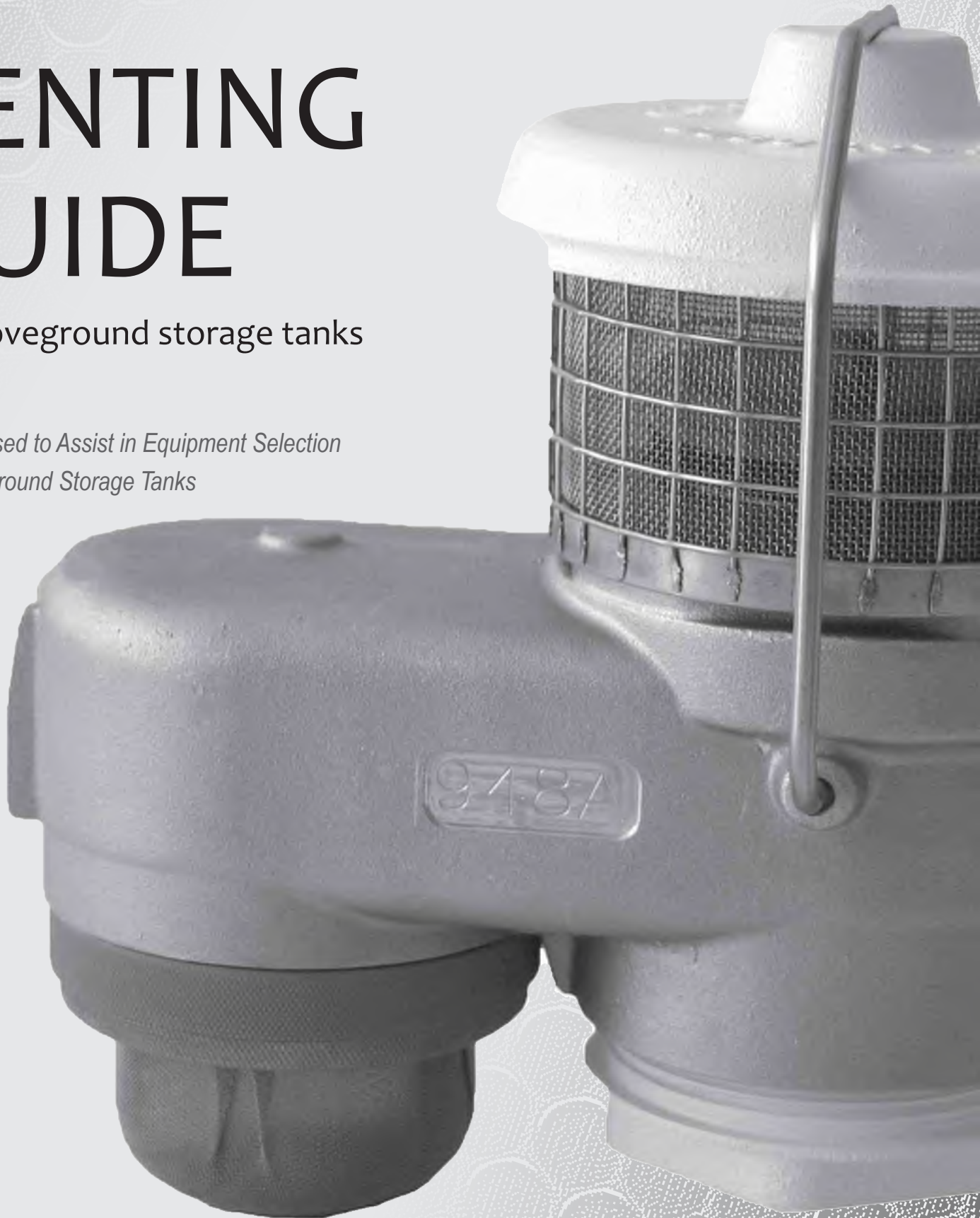



Contents

	Page
I. Background Information	
Introduction	1
Definitions	1
II. Example Calculations for Vent Selection	
Horizontal Cylindrical Storage Tank	2
Vertical Cylindrical Storage Tank	3
Horizontal Rectangular Storage Tank	4
Vent Combination Examples	5
III. Calculation Tables	
Pre-calculated Horizontal Cylindrical Tanks	6-7
Pre-calculated Vertical Cylindrical Storage Tanks	8-9
Pre-calculated Horizontal Rectangular Storage Tanks	10
Wetted Areas for Horizontal Cylindrical Tanks	11
Wetted Areas for Vertical Cylindrical Tanks	12
Emergency Venting Capacity	13
Gallon Capacity per Foot of Length	14
IV. Vent Selection	
Vent Capacity	14-15
Morrison Emergency Vent Specifications	16-18
Morrison Venting Equipment	19-25
V. Aboveground Fuel Storage Diagrams	
Pressure Systems	27-28
Suction Systems	29-30
Generator	31
Bulk Storage	32

References

NFPA 30	"Flammable and Combustible Liquids Code" 2015 Edition. National Fire Protection Association, 1 Batterymarch Park, Quincy, MA 02269
UL 142	"Steel Aboveground Tanks" 9th Edition. July 19, 2013. UL Standards for Safety—UL Publication Stock, 333 Pfingsten Road, Northbrook, IL 60062. Tel (847) 272-8800
ULC S601-07	Standard for Shop Fabricated Steel Aboveground Tanks for Flammable and Combustible Liquids. December 2007. Underwriters' Laboratories of Canada 7 Underwriters Rd., Toronto, ON M1R 3B4. Tel (514) 757-3611
PEI RP200	"Recommended Practices for Installation of Aboveground Storage Systems for Motor Vehicle Fueling." Petroleum Equipment Institute, 2008 Edition. P.O. Box 2380. Tulsa, OK, 74101; Tel (918) 494-9696
OSHA 1910.106	Occupational Safety and Health Standards. March 1, 2016. Occupational Safety and Health Administration, 200 Constitution Ave., NW, Washington, DC 20210. Tel (800) 321-6742
API 2000	Venting Atmospheric and Low-Pressure Storage Tanks. 1998. API, 1220 L Street, NW, Washington, DC 20005-4070. Tel (202) 682-8000
Morrison Bros. Co.	507 East 7th Street, Dubuque, Iowa 52001. Tel (563) 583-5701



Background Information

The Morrison Bros. Co. Venting Guide was created to assist in the selection of venting equipment for aboveground storage tanks. Examples on the next two pages illustrate a vent selection process. It is best to work through the examples before attempting to use any of the tables in this book.

Tables include examples for standard sized tanks. The venting capacity charts and wetted area tables were taken directly from NFPA 30 and UL 142.

The vent selection chapter includes venting capacities of specific Morrison vents. This data was obtained from results of laboratory testing and engineering calculations. Catalog pages of the Morrison equipment follow the vent capacity chart.

Definitions

Emergency Venting — Venting sufficient to relieve excessive internal pressure in storage tanks caused by exposure fires. Venting rate may exceed requirements of normal atmospheric and product transfer effects. In such cases, the construction of the tank will determine if additional venting capacity must be provided.

Atmospheric Tank — A storage tank that has been designed to operate at pressures from atmospheric through a gauge pressure of 1.0 psi (6.9 kPa) (i.e., 760 mm Hg through 812 mm Hg) measured at the top of the tank.

Normal Vent — An opening, construction method, or device that allows the relief of excessive internal pressure or vacuum during normal storage and operations.

Pressure Relieving Devices — Defined in NFPA 30 section 22.7.3.1, where entire dependence for emergency relief is placed upon pressure relieving devices, the total venting capacity of both normal and emergency vents shall be enough to prevent rupture of the shell or bottom of the tank if vertical, or of the shell or heads if horizontal.

Wetted Area — Exposed surface or shell area of a tank used in determining the venting requirements needed for that size tank in event of an exposure fire. In a horizontal tank, the wetted area is calculated as 75% of the exposed surface area. In a vertical tank, the wetted area is calculated as the first 30 ft. above grade of the exposed shell area of the tank. In a rectangular tank, the wetted area is calculated as the total surface area of the tank bottom and the four sides, excluding the tank top.

SCFH — Abbreviation for Standard Cubic Feet per Hour used to quantify or measure the airflow and degree of pressure relief for venting calculations.

Vent Capacity — The maximum rate of airflow (SCFH) recorded under test conditions at a maximum pressure of 2.5 PSI for specific sized emergency vents. This capacity rating is often required to be indicated on the vent itself.



Vent Selection/Capacity Example 1

HORIZONTAL CYLINDRICAL STORAGE TANK

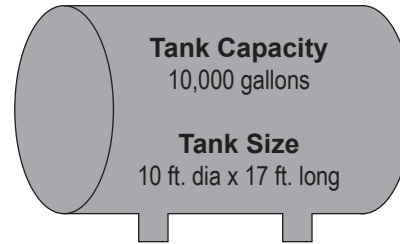

STEP 1 Pre-calculated Data for Common Sizes

Find tank size on Table A which can be found on page 6. Table lists wetted area and SCFH for common sized horizontal tanks. For a 10' x 17' tank – wetted area = 518 sq. ft. and required vent capacity = 360,840 SCFH. Proceed to Step 5.

STEP 2 Wetted Area Table

If tank size is NOT listed on Table A, page 6, wetted area can also be found on Table D, page 11. Follow grid for this example – 10' diameter x 17' length = 518 sq. ft. Proceed to Step 4.

STEP 3 Calculate Wetted Area

If the tank size is NOT on either chart, wetted area can be calculated. For Horizontal Tanks, wetted area = 75% of the total exposed surface area.

For a 10' x 17' tank—

$$0.75[2(\text{area of each end}) + (\text{area of shell})] = \text{wetted area}$$

$$\pi = 3.14, d = \text{diameter}, L = \text{length}, WA = \text{wetted area}$$

$$WA = 0.75[(\pi d^2 \div 2) + (\pi dL)]$$

$$0.75[((3.14)(10^2) \div 2) + (3.14)(10)(17)]$$

$$WA = 518 \text{ sq. ft.}$$

STEP 4 Determine SCFH Requirement

Use Table F: Venting Capacity Chart on page 13. Wetted area must be known (518 sq. ft.). Since 518 is between 500 and 600 on the chart, interpolation is needed and is done as follows:

	600 sq. ft.	392,000	SCFH
	<u>500 sq. ft.</u>	<u>354,000</u>	SCFH
Difference =	100 sq. ft.	38,000	SCFH

$$\frac{38,000}{100} = \frac{x}{(518-500)} \quad x = 6,840 \text{ SCFH}$$

$$\text{Total SCFH Required: } (6,840 + 354,000) = 360,840 \text{ SCFH}$$

STEP 5 Vent Selection

Options based on size of piping, type of product, flow requirements, required venting capacity and mounting. For the sake of this example, use 2" piping, Class 1B liquid. The normal vent size should be no smaller than the system piping, so a Morrison 2" Fig. 748A (20,000 SCFH) is selected.

Total required venting capacity for this tank example was determined to be 360,840 SCFH. Normal venting and emergency venting may be combined to reach this total. Morrison Vent Capacities are listed on Table H, page 15. Since the 6" Emergency Vent (299,684 SCFH) can not provide enough additional capacity to meet the requirement, an 8" Emergency Vent (503,517 SCFH) is selected. In specifying pressure settings, it is recommended that the Emergency Vent NOT be less than the normal vent. Therefore, the vent specification for this example is as follows:

Normal Vent - 2" Fig 748A	20,000	SCFH
(8 oz pressure - 1 oz vacuum)		
Emergency Vent - 8" Fig 244O	<u>503,517</u>	SCFH
(16 oz pressure)		
Total Venting Provided	523,517	SCFH

STEP 6 Verification

Refer to Table I on page 16 showing vent combinations and verify the total SCFH figure. Also refer to the product illustrations on pages 17-26 and verify the selection for correct option on material compatibility and mounting requirements.



Vent Selection/Capacity Example 2

VERTICAL CYLINDRICAL STORAGE TANK

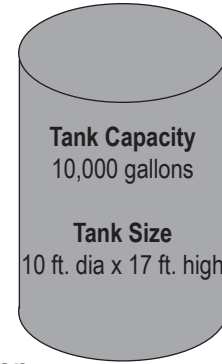

STEP 1 Pre-calculated Data for Common Sizes

Find tank size on Table B which can be found on page 8-9. Table lists wetted area and SCFH for common sized vertical tanks. For a 10' x 17' tank – wetted area = 534 sq. ft. and required vent capacity = 366,920 SCFH. Proceed to Step 5.

STEP 2 Wetted Area Table

If tank size is NOT listed on Table B, page 8-9, wetted area can also be found on Table E, page 12. Follow grid for this example – 10' diameter x 17' height = 534 sq. ft. Proceed to Step 4.

STEP 3 Calculate Wetted Area

If the tank size is NOT on either chart, wetted area can be calculated. For Vertical Tanks, wetted area = area of shell to elevation not more than 30 ft. above the bottom.

For a 10' x 17' tank:

Wetted Area = (area of shell)

$\pi = 3.14$, d = diameter, L = length, WA = wetted area

$$WA = (\pi d)L$$

$$(3.14)(10)(17)$$

$$WA = 534 \text{ sq. ft.}$$

STEP 4 Determine SCFH Requirement

Use Table F: Venting Capacity Chart on page 13. Wetted area must be known (534 sq. ft.). Since 534 is between 500 and 600 on the chart, interpolation is needed and is done as follows:

	600 sq. ft.	392,000	SCFH
	<u>500 sq. ft.</u>	<u>354,000</u>	SCFH
Difference =	100 sq. ft.	38,000	SCFH

$$38,000 = \frac{x}{(534-500)} \quad x = 12,920 \text{ SCFH}$$

Total SCFH Required: (12,920 + 354,000) = 366,920 SCFH

STEP 5 Vent Selection

Options based on size of piping, type of product, flow requirements, required venting capacity and mounting. For the sake of this example, use 2" piping, Class 1B liquid. The normal vent size should be no smaller than the system piping, so a Morrison 2" Fig. 748A (20,000 SCFH) is selected.

Total required venting capacity for this tank example was determined to be 366,920 SCFH. Normal venting and emergency venting may be combined to reach this total. Morrison Vent Capacities are listed on Table H, page 15. Since the 6" Emergency Vent (299,684 SCFH) can not provide enough additional capacity to meet the requirement, an 8" Emergency Vent (503,517 SCFH) is selected. In specifying pressure settings, it is recommended that the Emergency Vent NOT be less than the normal vent. Therefore, the vent specification for this example is as follows:

Normal Vent - 2" Fig 748A	20,000	SCFH
(8 oz pressure - 1 oz vacuum)		
Emergency Vent - 8" Fig 244O	<u>503,517</u>	SCFH
(16 oz pressure)		
Total Venting Provided	523,517	SCFH

STEP 6 Verification

Refer to Table I on page 16 showing vent combinations and verify the total SCFH figure. Also refer to the product illustrations on pages 17-26 and verify the selection for correct option on material compatibility and mounting requirements.



Vent Selection/Capacity Example 3

HORIZONTAL RECTANGULAR STORAGE TANK

Tank Capacity
10,000 gallons

Tank Size
274"L x 130"W x 65"H
(22'-10"L x 10'-10"W x 5'5"H)

STEP 1 Pre-calculated Data for Common Sizes

Find tank size on Table C which can be found on page 10. Table lists wetted area and SCFH for common sized tanks. For a 274"L x 130"W x 65"H (22'-10"L x 10'-10"W x 5'5"H) tank – wetted area = 612 sq. ft. and required vent capacity = 396,320 SCFH. Proceed to Step 4.

STEP 2 Wetted Area Table

If tank size is NOT listed on Table C, page 10, wetted area can be calculated. For Horizontal Rectangular Tanks, wetted area = exposed shell area excluding the top surface of the tank.

For a 274"L x 130"W x 65"H tank:

$$\text{Wetted area} = \frac{(L \times W) + 2(L \times H) + 2(W \times H)}{144}$$

L = length, W = width, H = height

$$\frac{(274 \times 130) + 2(274 \times 65) + 2(130 \times 65)}{144}$$

Wetted Area = 612 Sq. ft.

STEP 3 Determine SCFH Requirement

Use Table F: Venting Capacity Chart on page 13. Wetted area must be known (612 sq. ft.). Since 612 is between 600 and 700 on the chart, interpolation is needed and is done as follows:

	700 sq. ft.	428,000	SCFH
	<u>600 sq. ft.</u>	<u>392,000</u>	SCFH
Difference =	100 sq. ft.	36,000	SCFH

$$\frac{36,000}{100} = \frac{x}{(612-600)} \quad x = 4,320 \text{ SCFH}$$

Total SCFH Required: (4,320 + 392,000) = 396,320 SCFH

STEP 4 Vent Selection

Options based on size of piping, type of product, flow requirements, required venting capacity and mounting. For the sake of this example, use 2" piping, Class 1B liquid. The normal vent size should be no smaller than the system piping, so a Morrison 2" Fig. 748A (20,000 SCFH) is selected.

Total required venting capacity for this tank example was determined to be 396,320 SCFH. Normal venting and emergency venting may be combined to reach this total. Morrison Vent Capacities are listed on Table H, page 15. Since the 6" Emergency Vent (299,684 SCFH) can not provide enough additional capacity to meet the requirement, an 8" Emergency Vent (503,517 SCFH) is selected. In specifying pressure settings, it is recommended that the Emergency Vent NOT be less than the normal vent. Therefore, the vent specification for this example is as follows:

Normal Vent - 2" Fig 748A	20,000	SCFH
(8 oz pressure - 1 oz vacuum)		
Emergency Vent - 8" Fig 2440	<u>503,517</u>	SCFH
(16 oz pressure)		
Total Venting Provided	523,517	SCFH

STEP 5 Verification

Refer to Table I on page 16 showing vent combinations and verify the total SCFH figure. Also refer to the product illustrations on pages 17-26 and verify the selection for correct option on material compatibility and mounting requirements.



Table I: Vent Combination Examples

	MORRISON VENTS	SCFH		MORRISON VENTS	SCFH
1.	2" Fig. 748A - 4 oz P	20,000	7.	2" Fig. 749 - 8 oz P	8,500
	4" Fig. 244O - 8 oz P	<u>131,700</u>		4" Fig. 244O - 16 oz P	<u>131,700</u>
	TOTAL SCFH	151,700		TOTAL SCFH	140,200
2.	2" Fig. 748A - 8 oz P	20,000	8.	3" Fig. 748A - 8 oz P	43,000
	6" Fig. 244O - 16 oz P	<u>299,684</u>		6" Fig. 244O - 16 oz P	<u>299,684</u>
	TOTAL SCFH	319,684		TOTAL SCFH	342,684
3.	2" Fig. 748A - 8 oz P	20,000	9.	3" Fig. 748A - 8 oz P	43,000
	8" Fig. 244O - 16 oz P	<u>503,517</u>		8" Fig. 244O - 16 oz P	<u>503,517</u>
	TOTAL SCFH	523,517		TOTAL SCFH	546,517
4.	2" Fig. 748A - 8 oz P	20,000	10.	3" Fig. 922 - 8 oz P	30,300
	10" Fig. 244OF - 16 oz P	<u>890,275</u>		10" Fig. 244OF - 16 oz P	<u>890,275</u>
	TOTAL SCFH	910,275		TOTAL SCFH	920,575
5.	2" Fig. 948A - 2.5-6"wc P	36,720	11.	3" Fig. 748A - 8 oz P	43,000
	10" Fig. 244OF - 8 oz P	<u>890,275</u>		10" Fig. 244OF - 8 oz P	<u>890,275</u>
	TOTAL SCFH	926,995		TOTAL SCFH	933,275
6.	3" Fig. 748A - 8 oz P	43,000	12.	4" Fig. 354	116,900
	10" Fig. 244OF - 10 oz P	<u>890,275</u>		10" Fig. 244OF - 8 oz P	<u>890,275</u>
	TOTAL SCFH	933,275		TOTAL SCFH	1,007,175

Note: All calculations above are less screens.

**Table A: Pre-Calculated Data****HORIZONTAL CYLINDRICAL TANKS**

TANK			WETTED AREA (Sq Ft)	REQ'D VENT CAPACITY (SCFH)	EMERGENCY VENT SIZE WITHOUT SCREEN (Inches)	EMERGENCY VENT SIZE WITH SCREEN (Inches)
CAPACITY (Gallons)	DIAMETER (Ft or In)	LENGTH (Ft-In)				
280	36"	5'-2"	47	49,520	3	3
300	38"	5'-0"	49	51,640	3	4
500	48"	5'-5"	69	72,650	4	4
530	46"	6'-0"	71	74,750	4	4
550	48"	6'-0"	75	78,950	4	4
1,000	48"	10'-8"	119	124,950	4	5
1,000	64"	6'-0"	109	114,450	4	4
1,500	64"	9'-0"	147	154,350	5	5
2,000	64"	12'-0"	184	193,200	6	6
2,500	64"	15'-0"	222	223,320	6	6
3,000	64"	18'-0"	259	243,680	6	6
3,000	6'-0"	14'-0"	240	233,400	6	6
4,000	64"	24'-0"	335	281,100	6	NA
4,000	6'-0"	19'-0"	311	270,060	6	NA
5,000	8'-0"	13'-4"	326	276,960	6	NA
6,000	8'-0"	16'-0"	376	300,480	8	NA
8,000	8'-0"	21'-4"	477	344,340	8	NA
10,000	8'-0"	27'-0"	584	385,920	8	NA
10,000	9'-0"	21'-0"	540	369,200	8	NA
10,000	10'-0"	17'-0"	518	360,840	8	NA
10,000	10'-6"	15'-7"	515	359,700	8	NA
12,000	8'-0"	32'-0"	678	420,080	8	NA
12,000	9'-0"	25'-0"	625	401,000	8	NA
12,000	10'-0"	20'-6"	600	392,000	8	NA
12,000	11'-0"	17'-0"	583	385,540	8	NA
15,000	8'-0"	40'-0"	829	470,990	8	NA
15,000	10'-6"	23'-5"	703	429,020	8	NA
20,000	10'-0"	34'-2"	922	499,820	8	NA
20,000	10'-6"	31'-0"	896	491,760	8	NA
20,000	11'-0"	28'-0"	868	483,080	8	NA
25,000	10'-6"	38'-6"	1,082	537,530	10	NA

(TABLE CONTINUES ON NEXT PAGE)



Table A: Pre-Calculated Data

HORIZONTAL CYLINDRICAL TANKS (CONTINUED)

TANK			WETTED AREA (Sq Ft)	REQ'D VENT CAPACITY (SCFH)	EMERGENCY VENT SIZE WITHOUT SCREEN (Inches)	EMERGENCY VENT SIZE WITH SCREEN (Inches)
CAPACITY (Gallons)	DIAMETER (Ft or In)	LENGTH (Ft-In)				
30,000	10'-0"	51'-2"	1,324	575,600	10	NA
30,000	10'-6"	46'-3"	1,274	568,100	10	NA
40,000	12'-0"	47'-6"	1,512	602,120	10	NA
50,000	12'-0"	59'-6"	1,852	664,980	10	NA
50,000	12'-6"	54'-6"	1,789	637,735	10	NA
60,000	12'-0"	71'-0"	2,177	680,585	10	NA
60,000	12'-6"	65'-5"	2,110	637,550	10	NA
60,000	13'-0"	60'-6"	2,052	667,460	10	NA
70,000	13'-0"	72'-0"	2,404	704,380	10	NA

Table B: Pre-Calculated Data

VERTICAL CYLINDRICAL TANKS

TANK			WETTED AREA (Sq Ft)	REQ'D VENT CAPACITY (SCFH)	EMERGENCY VENT SIZE WITHOUT SCREEN (Inches)	EMERGENCY VENT SIZE WITH SCREEN (Inches)
CAPACITY (Gallons)	DIAMETER (Ft or In)	LENGTH (Ft-In)				
280	36"	5'-2"	48	50,580	3	3
300	38"	5'-0"	49	51,640	3	4
500	48"	5'-5"	68	71,600	4	4
530	46"	6'-0"	72	75,800	4	4
550	48"	6'-0"	75	78,950	4	4
1,000	48"	10'-8"	134	140,700	5	5
1,000	64"	6'-0"	100	105,000	5	5
1,500	64"	9'-0"	151	158,550	5	5
2,000	64"	12'-0"	201	213,100	6	6
2,500	64"	15'-0"	251	239,520	6	6
3,000	6'-0"	14'-0"	263	245,760	6	6
3,000	64"	18'-0"	301	265,460	6	NA
4,000	64"	24'-0"	402	312,840	8	NA
4,000	6'-0"	19'-0"	358	291,840	6	NA
5,000	8'-0"	13'-4"	335	281,100	6	NA
6,000	8'-0"	16'-0"	402	312,840	8	NA
8,000	8'-0"	21'-4"	536	367,680	8	NA
10,000	8'-0"	27'-0"	678	420,080	8	NA
10,000	9'-0"	21'-0"	593	389,340	8	NA
10,000	10'-0"	17'-0"	534	366,920	8	NA
10,000	10'-6"	15'-7"	514	359,320	8	NA
12,000	8'-0"	32'-0"	754	446,360	8	NA
12,000	9'-0"	25'-0"	706	430,040	8	NA
12,000	10'-0"	20'-6"	644	407,840	8	NA
12,000	11'-0"	17'-0"	587	387,060	8	NA
15,000	8'-0"	40'-0"	754	446,360	8	NA
15,000	10'-6"	23'-5"	764	449,760	8	NA
20,000	10'-0"	34'-2"	942	506,020	10	NA
20,000	10'-6"	31'-0"	990	520,900	10	NA
20,000	11'-0"	28'-0"	967	513,770	10	NA
25,000	10'-6"	38'-6"	990	520,900	10	NA



Table B: Pre-Calculated Data

VERTICAL CYLINDRICAL TANKS (CONTINUED)

TANK			WETTED AREA (Sq Ft)	REQ'D VENT CAPACITY (SCFH)	EMERGENCY VENT SIZE WITHOUT SCREEN (Inches)	EMERGENCY VENT SIZE WITH SCREEN (Inches)
CAPACITY (Gallons)	DIAMETER (Ft or In)	LENGTH (Ft-In)				
30,000	10'-6"	46'-3"	990	520,900	10	NA
30,000	12'-0"	35'-6"	1,131	545,615	10	NA
30,000	12'-6"	32'-9"	1,176	553,040	10	NA
40,000	12'-0"	47'-6"	1,131	545,615	10	NA
40,000	12'-6"	43'-8"	1,178	553,370	10	NA
40,000	13'-0"	40'-4"	1,225	560,750	10	NA
49,500	13'-0"	50'-0"	1,225	560,750	10	NA
57,000	14'-0"	50'-0"	1,319	574,850	10	NA

Table C: Pre-Calculated Data

HORIZONTAL RECTANGULAR TANKS

TANK				WETTED AREA (Sq Ft)	REQ'D VENT CAPACITY (SCFH)	EMERGENCY VENT SIZE WITHOUT SCREEN (Inches)	EMERGENCY VENT SIZE WITH SCREEN (Inches)
CAPACITY (Gallons)	LENGTH (Ft-In)	WIDTH (Ft-In)	HEIGHT (Ft-In)				
125	6'-8"	2'-9"	1'-0"	37	38,950	3	3
186	2'-8"	2'-8"	3'-6"	44	46,340	3	3
250	4'-4"	4'-0"	1'-11"	49	51,640	3	4
250	6'-8"	2'-9"	1'-11"	54	56,900	3	4
500	7'-6"	3'-0"	3'-0"	86	90,560	4	4
500	10'-0"	3'-6"	2'-0"	89	93,740	4	4
1,000	9'-8"	4'-8"	3'-0"	131	137,550	5	5
1,000	10'-0"	4'-7"	2'-11"	133	139,650	5	5
2,000	10'-2"	6'-11"	3'-10"	201	211,560	6	6
2,000	10'-8"	6'-4"	4'-0"	204	213,240	6	6
2,500	10'-2"	6'-11"	4'-9"	233	229,480	6	6
3,000	8'-6"	6'-10"	7'-2"	278	253,560	6	NA
3,000	13'-9"	5'-5"	5'-5"	282	255,640	6	NA
4,000	11'-4"	6'-10"	7'-2"	338	282,480	6	NA
4,000	18'-2"	5'-5"	5'-5"	354	289,920	6	NA
5,000	22'-9"	5'-5"	5'-5"	428	323,760	8	NA
6,000	13'-8"	10'-10"	5'-5"	413	317,460	8	NA
6,000	16'-5"	6'-10"	7'-2"	445	330,900	8	NA
6,000	27'-4"	5'-5"	5'-5"	503	355,140	8	NA
8,000	18'-2"	10'-10"	5'-5"	511	358,180	8	NA
8,000	21'-11"	6'-10"	7'-2"	562	377,560	8	NA
10,000	22'-10"	10'-10"	5'-5"	612	396,320	8	NA
10,000	27'-5"	6'-10"	7'-2"	678	420,080	8	NA
12,000	27'-4"	10'-10"	5'-5"	710	431,400	8	NA
12,000	32'-11"	6'-10"	7'-2"	795	460,300	8	NA



Table D: Approximate Wetted Areas

HORIZONTAL CYLINDRICAL TANKS

Tank Diameter	3 Ft	4 Ft	5 Ft	6 Ft	7 Ft	8 Ft	9 Ft	10 Ft	11 Ft	12 Ft	13 Ft
Tank Length	<i>Approximate Wetter Area of Tanks With Flat Heads, Square Feet</i>										
3 Ft	32										
4 Ft	39	55									
5 Ft	46	65	88								
6 Ft	53	74	100	128							
7 Ft	60	84	112	142	173						
8 Ft	67	93	124	156	190	226					
9 Ft	74	102	136	170	206	245	286				
10 Ft	81	112	147	184	223	264	308	353			
11 Ft	88	121	159	198	239	283	329	377	428		
12 Ft	95	131	171	213	256	301	350	400	454	509	
13 Ft	102	140	183	227	272	320	371	424	480	537	598
14 Ft	109	150	194	241	289	339	393	447	506	565	628
15 Ft	116	159	206	255	305	358	414	471	532	594	659
16 Ft	123	169	218	269	322	377	435	495	558	622	690
17 Ft	130	178	230	283	338	395	456	518	584	650	720
18 Ft	137	188	242	298	355	414	477	542	610	678	751
19 Ft		197	253	312	371	433	499	565	636	707	781
20 Ft		206	265	326	388	452	520	589	662	735	812
21 Ft		216	277	340	404	471	541	612	688	763	843
22 Ft		225	289	354	421	490	562	636	714	792	873
23 Ft		235	300	368	437	508	584	659	740	820	904
24 Ft		244	312	383	454	527	605	683	765	848	935
25 Ft			324	397	470	546	626	706	791	876	965
26 Ft			336	411	487	565	647	730	817	905	996
27 Ft			347	425	503	584	668	754	843	933	1027
28 Ft			359	440	520	603	690	777	869	961	1057
29 Ft			371	454	536	621	711	801	895	989	1088
30 Ft			383	468	553	640	732	824	921	1018	1118
31 Ft			395	482	569	659	753	848	947	1046	1149
32 Ft				496	586	678	775	871	973	1074	1180
33 Ft				510	602	697	796	895	999	1103	1210
34 Ft				524	619	715	817	918	1025	1131	1241
35 Ft				539	635	734	838	942	1051	1159	1272
36 Ft				553	652	753	860	966	1077	1187	1302
37 Ft				567	668	772	881	989	1103	1216	1333

Tank Diameter	3 Ft	4 Ft	5 Ft	6 Ft	7 Ft	8 Ft	9 Ft	10 Ft	11 Ft	12 Ft	13 Ft
Tank Length	<i>Approximate Wetter Area of Tanks With Flat Heads, Square Feet</i>										
38 Ft					685	791	902	1013	1129	1244	1363
39 Ft					701	810	923	1036	1155	1272	1394
40 Ft					718	828	944	1060	1181	1301	1425
41 Ft					734	847	966	1083	1207	1329	1455
42 Ft					751	866	987	1107	1233	1357	1486
43 Ft					767	885	1008	1130	1259	1385	1517
44 Ft						904	1029	1154	1284	1414	1547
45 Ft						923	1051	1178	1310	1442	1578
46 Ft						941	1072	1201	1336	1470	1609
47 Ft						960	1093	1225	1362	1498	1639
48 Ft						979	1114	1248	1388	1527	1670
49 Ft							1135	1272	1414	1555	1700
50 Ft							1157	1295	1440	1583	1731
51 Ft							1178	1319	1466	1612	1762
52 Ft							1199	1342	1492	1640	1792
53 Ft							1220	1366	1518	1668	1823
54 Ft							1246	1389	1544	1697	1854
55 Ft							1263	1413	1570	1725	1884
56 Ft								1437	1593	1753	1915
57 Ft								1460	1622	1781	1945
58 Ft								1484	1648	1809	1976
59 Ft								1507	1674	1839	2007
60 Ft								1531	1700	1867	2037
61 Ft									1726	1895	2068
62 Ft									1752	1923	2099
63 Ft									1778	1951	2129
64 Ft									1803	1980	2160
65 Ft									1829	2007	2190
66 Ft									1855	2036	2221
67 Ft										2064	2252
68 Ft										2093	2282
69 Ft										2121	2313
70 Ft										2149	2343
71 Ft										2177	2374
72 Ft										2205	2405

SI Units: 1 Ft = 0.30 m; 1 sq ft = 0.09 sq m
 Source for Chart: UL 142, Table A-2, 9th Edition, July 19, 2013

Table E: Approximate Wetted Areas

VERTICAL CYLINDRICAL TANKS

(Area of Shell to Elevation Not More Than 30 Ft. Above Bottom)

Tank Diameter	3 Ft	4 Ft	5 Ft	6 Ft	7 Ft	8 Ft	9 Ft	10 Ft	11 Ft	12 Ft	13 Ft	14 Ft
Tank Length	<i>Wetted Area, Square Feet</i>											
3 Ft	28											
4 Ft	38	50										
5 Ft	47	63	79									
6 Ft	56	76	94	113								
7 Ft	66	88	110	132	154							
8 Ft	75	101	127	151	176	201						
9 Ft	85	113	141	170	198	226	255					
10 Ft	94	126	157	189	220	251	283	314				
11 Ft	103	139	173	208	242	276	311	345	381			
12 Ft	113	151	188	227	264	301	340	377	415	452		
13 Ft		164	204	246	286	326	368	408	450	490	531	
14 Ft		176	220	265	308	351	396	440	484	528	572	616
15 Ft		189	236	284	330	377	424	471	519	566	613	660
16 Ft		202	251	302	352	402	453	502	554	603	654	704
17 Ft			267	321	374	427	481	534	588	641	695	748
18 Ft			283	340	396	452	510	565	623	679	735	792
19 Ft			298	359	418	477	538	597	657	716	776	836
20 Ft			314	378	440	502	566	628	692	754	817	880
21 Ft				397	462	527	594	659	727	792	858	924
22 Ft				416	484	552	623	691	761	829	899	968
23 Ft				435	506	577	651	722	796	867	940	1012
24 Ft				454	528	602	679	757	830	905	981	1056
25 Ft					550	628	708	785	865	943	1021	1100
26 Ft					572	653	736	816	900	980	1062	1144
27 Ft					594	678	764	848	934	1018	1103	1188
28 Ft					616	703	792	879	969	1056	1144	1232
29 Ft						728	821	911	1003	1093	1185	1275
30 Ft						753	849	942	1038	1131	1226	1319

SI Units: 1 Ft = 0.30 m; 1 sq ft = 0.09 sq m

Source for Chart: UL 142, Table A-3, 9th Edition, July 19, 2013



Table F: Emergency Venting Capacity

Wetted surface, square feet ^a	Venting capacity, standard cubic feet per hour ^b	Minimum opening, nominal pipe size, inches
20	21,100	2
30	31,600	2
40	42,100	3
50	52,700	3
60	63,200	3
70	73,700	4
80	84,200	4
90	94,800	4
100	105,000	4
120	126,000	5
140	147,000	5
160	168,000	5
180	190,000	5
200	211,000	6
250	239,000	6
300	265,000	6
350	288,000	8
400	312,000	8
500	354,000	8
600	392,000	8
700	428,000	8
800	462,000	8
900	493,000	8
1000	524,000	10
1200	557,000	10
1400	587,000	10
1600	614,000	10
1800	639,000	10
2000	662,000	10
2400	704,000	10
2800	742,000	10
3200	776,000	12
3600 and over	806,000	12

^a Interpolate for intermediate values.

^b These values taken from NFPA 30–2015, Table 22.7.3.2

Notes:

- Emergency venting capacity is based on atmospheric pressure of 14.7 psia and 60° F (101.4 kPa and 16° C).
- These pipe sizes apply only to open vent pipes to the specified diameter not more than 12 inches (0.3m) long and a pressure in tank of not more than 2.5 psig (17.1 kPa).
- If tank is to be equipped with a venting device or flame arrestor, the vent opening is to accommodate the venting device or flame arrestor in accordance with the listed SCFH.

NFPA 30 — 2015

Normal Venting Recommendations

21.4.3.3 Normal vents shall be sized in accordance with either API Standard 2000, Venting Atmospheric and Low-Pressure Storage Tanks, or another approved standard. Alternatively, the normal vent shall be at least as large as the largest filling or withdrawal connection, but in no case shall it be less than 1¼ in. (3.2 cm) nominal inside diameter.



Table G: Gallon Capacity Per Foot of Length

Diameter (Inches)	U.S. Gallons Per Ft Length	Diameter (Inches)	U.S. Gallons Per Ft Length	Diameter (Inches)	U.S. Gallons Per Ft Length	Diameter (Inches)	U.S. Gallons Per Ft Length
24	23.50	56	127.95	88	315.95	120	587.52
25	25.50	57	132.56	89	323.18	121	597.70
26	27.58	58	137.25	90	330.48	122	607.27
27	29.74	59	142.02	91	337.86	123	617.26
28	31.99	60	146.88	92	345.33	124	627.00
29	34.31	61	151.82	93	352.88	125	638.20
30	36.72	62	156.83	94	360.51	126	647.74
31	39.21	63	161.93	95	368.22	127	658.60
32	41.78	64	167.12	96	376.01	128	668.47
33	44.43	65	172.38	97	383.89	129	678.95
34	47.16	66	177.72	98	391.84	130	690.30
35	49.98	67	183.15	99	399.88	131	700.17
36	52.88	68	188.66	100	408.00	132	710.90
37	55.86	69	194.25	101	416.00	133	721.71
38	58.92	70	199.92	102	424.48	134	732.60
39	62.06	71	205.67	103	433.10	135	743.58
40	65.28	72	211.51	104	441.80	136	754.64
41	68.58	73	217.42	105	449.82	137	765.78
42	71.97	74	223.42	106	458.30	138	776.99
43	75.44	75	229.50	107	467.70	139	788.30
44	78.99	76	235.66	108	475.89	140	799.68
45	82.62	77	241.90	109	485.00	141	811.14
46	86.33	78	248.23	110	493.70	142	822.69
47	90.13	79	254.63	111	502.70	143	834.32
48	94.00	80	261.12	112	511.90	144	846.03
49	97.96	81	267.69	113	521.40		
50	102.00	82	274.34	114	530.24		
51	106.12	83	281.07	115	540.00		
52	110.32	84	287.88	116	549.50		
53	114.61	85	294.78	117	558.51		
54	118.97	86	301.76	118	568.00		
55	123.42	87	308.81	119	577.80		

Table H: Vent Capacity

SIZE	FIG. NO.	MOUNTING CONNECTION	DESCRIPTION	PRESSURE oz/sq in.	CAPACITY SCFH	DATA SOURCE
1½"	354	Female Slip On	Updraft Vent	0	27,650	Tested at Iowa State University by P. Kavanagh, 1990
2"	244OM	Male Threads	Emergency Vent	8	31,917	Colorado Engineering Experiment Station Inc., 2014
2"	244OMS	Male Threads	Emergency Vent w/ Screen	8	24,069	Colorado Engineering Experiment Station Inc., 2014
2"	245M	Male Threads	Emergency Vent	8	31,917	Colorado Engineering Experiment Station Inc., 2014
2"	245MS	Male Threads	Emergency Vent w/ Screen	8	24,069	Colorado Engineering Experiment Station Inc., 2014
2"	351S	Female Threads	Flame Arrester	0	22,000	Tested at Ohio State Univ. by O. E. Buxton Jr. 1967
2"	351S/748A	Female Threads	Flame Arrester/Vent	2, 4, 6, or 8	15,500	Based on ISU Test of 2" 351S/548-748 - 8 oz. by Kavanagh, 1990
2"	351S/748A	Female Threads	Flame Arrester/Vent	12 or 16	13,000	Based on ISU Test of 2" 351S/548-748 - 8 oz. by Kavanagh, 1990
2"	354	Female Slip On	Updraft Vent	0	27,650	Tested at Univ. Wisconsin Platteville by L. Lee, 1988
2"	748A	Female Threads	Pressure Vacuum Vent	2, 4, or 6	20,200	Based on ISU Test of 2" 548 - 8 oz. by Kavanagh, 1960
2"	748A	Female Threads	Pressure Vacuum Vent	8	20,000	Based on ISU Test of 2" 548 - 8 oz. by Kavanagh, 1960
2"	748A	Female Threads	Pressure Vacuum Vent	12	18,600	Based on ISU Test of 2" 548 - 8 oz. by Kavanagh, 1960
2"	748A	Female Threads	Pressure Vacuum Vent	16	18,600	Tested at Iowa State Univ. by P. Kavanagh, 1960
2"	749	Female Thds/Slip On	Pressure Vacuum Vent	8	8,500	Tested at Univ. of Wisconsin Platteville by L. Lee, 1988
2"	749	Female Thds/Slip On	Pressure Vacuum Vent	12	8,500	Tested at Univ. of Wisconsin Platteville by L. Lee, 1988

(TABLE H CONTINUES ON NEXT PAGE)

Table H: Vent Capacity (CONTINUED)

SIZE	FIG. NO.	MOUNTING CONNECTION	DESCRIPTION	PRESSURE oz/sq in.	CAPACITY SCFH	DATA SOURCE
2"	749 CRB	Female Thds/Slip On	Pressure Vacuum Vent	1.70	11,000	Tested at Univ. of Wisconsin Platteville by L. Lee, 1996
2"	922	Female Threads	Pressure Vacuum Vent Alarm	6	30,120	Tested at Environ Laboratories, 2006
2"	922	Female Threads	Pressure Vacuum Vent Alarm	8	30,300	Tested at Environ Laboratories, 2006
2"	948A	Female Threads	Pressure Vacuum Vent Alarm	2.5-6" WC	36,720	Tested at Underwriters Laboratories, 2012
3"	244OM	Male Threads	Emergency Vent	8 or 16	60,994	Colorado Engineering Experiment Station Inc., 2014
3"	244OMS	Male Threads	Emergency Vent w/ Screen	8 or 16	51,076	Colorado Engineering Experiment Station Inc., 2014
3"	244O	Female Threads	Emergency Vent	8 or 16	60,994	Colorado Engineering Experiment Station Inc., 2014
3"	244OS	Female Threads	Emergency Vent w/ Screen	8 or 16	51,076	Colorado Engineering Experiment Station Inc., 2014
3"	245M	Male Threads	Emergency Vent	8	67,162	Colorado Engineering Experiment Station Inc., 2018
3"	245MS	Male Threads	Emergency Vent w/ Screen	8	56,241	Colorado Engineering Experiment Station Inc., 2018
3"	245	Female Threads	Emergency Vent	8	67,162	Colorado Engineering Experiment Station Inc., 2018
3"	245S	Female Threads	Emergency Vent w/ Screen	8	56,241	Colorado Engineering Experiment Station Inc., 2018
3"	354	Female Slip On	Updraft Vent	0	59,000	Tested at Univ. Wisconsin Platteville by L. Lee, 1996
3"	749	Female Thds/Slip On	Pressure Vacuum Vent	8	8,500	Tested at Univ. of Wisconsin Platteville by L. Lee, 1988
3"	749	Female Thds/Slip On	Pressure Vacuum Vent	12	8,500	Tested at Univ. of Wisconsin Platteville by L. Lee, 1988
3"	749 CRB	Female Thds/Slip On	Pressure Vacuum Vent	1.70	11,000	Tested at Univ. of Wisconsin Platteville by L. Lee, 1996
3"	748A	Female Threads	Pressure Vacuum Vent	2, 4, 6, or 8	43,000	Based on ISU Test of 3" 548 - 8 oz. by Kavanagh, 1990
3"	748A	Female Threads	Pressure Vacuum Vent	12 or 16	40,000	Based on ISU Test of 3" 548 - 16 oz. by Kavanagh, 1990
3"	922	Female Threads	Pressure Vacuum Vent Alarm	6	44,160	Tested at Environ Laboratories, 2006
3"	922	Female Threads	Pressure Vacuum Vent Alarm	8	43,080	Tested at Environ Laboratories, 2006
4"	244OM	Male Threads	Emergency Vent	8 or 16	131,700	Colorado Engineering Experiment Station Inc., 2014
4"	244OMS	Male Threads	Emergency Vent w/ Screen	8 or 16	117,160	Colorado Engineering Experiment Station Inc., 2014
4"	244O	Female Threads	Emergency Vent	8 or 16	131,700	Colorado Engineering Experiment Station Inc., 2014
4"	244OS	Female Threads	Emergency Vent w/ Screen	8 or 16	117,160	Colorado Engineering Experiment Station Inc., 2014
4"	245M	Male Threads	Emergency Vent	8	129,369	Colorado Engineering Experiment Station Inc., 2018
4"	245MS	Male Threads	Emergency Vent w/ Screen	8	115,086	Colorado Engineering Experiment Station Inc., 2018
4"	245	Female Threads	Emergency Vent	8	129,369	Colorado Engineering Experiment Station Inc., 2018
4"	245S	Female Threads	Emergency Vent w/ Screen	8	115,086	Colorado Engineering Experiment Station Inc., 2018
4"	245F	Flanged	Emergency Vent	8	129,369	Colorado Engineering Experiment Station Inc., 2018
4"	245FS	Flanged	Emergency Vent w/ Screen	8	115,086	Colorado Engineering Experiment Station Inc., 2018
4"	354	Female Slip On	Updraft Vent	0	116,900	Tested at Continental Disc Corp, 1997
5"	244O	Female Threads	Emergency Vent	8 or 16	190,087	Colorado Engineering Experiment Station Inc., 2014
5"	244OS	Female Threads	Emergency Vent w/ Screen	8 or 16	165,756	Colorado Engineering Experiment Station Inc., 2014
5"	244OM	Male Threads	Emergency Vent	8 or 16	190,087	Colorado Engineering Experiment Station Inc., 2014
5"	244OMS	Male Threads	Emergency Vent w/ Screen	8 or 16	165,756	Colorado Engineering Experiment Station Inc., 2014
6"	244O	Female Threads	Emergency Vent	8 or 16	299,684	Colorado Engineering Experiment Station Inc., 2014
6"	244OS	Female Threads	Emergency Vent w/ Screen	8 or 16	250,236	Colorado Engineering Experiment Station Inc., 2014
6"	244OF	Flanged	Emergency Vent	8 or 16	299,684	Colorado Engineering Experiment Station Inc., 2014
6"	244OFS	Flanged	Emergency Vent w/ Screen	8 or 16	250,236	Colorado Engineering Experiment Station Inc., 2014
6"	244OM	Male Threads	Emergency Vent	8 or 16	299,684	Colorado Engineering Experiment Station Inc., 2014
6"	244OMS	Male Threads	Emergency Vent w/ Screen	8 or 16	250,236	Colorado Engineering Experiment Station Inc., 2014
6"	245M	Male Threads	Emergency Vent	8	331,750	Colorado Engineering Experiment Station Inc., 2018
6"	245MS	Male Threads	Emergency Vent w/ Screen	8	277,011	Colorado Engineering Experiment Station Inc., 2018
6"	245	Female Threads	Emergency Vent	8	331,750	Colorado Engineering Experiment Station Inc., 2018
6"	245S	Female Threads	Emergency Vent w/ Screen	8	277,011	Colorado Engineering Experiment Station Inc., 2018
6"	245F	Flanged	Emergency Vent	8	331,750	Colorado Engineering Experiment Station Inc., 2018
6"	245FS	Flanged	Emergency Vent w/ Screen	8	277,011	Colorado Engineering Experiment Station Inc., 2018
8"	244O	Female Threads	Emergency Vent	8 or 16	503,517	Colorado Engineering Experiment Station Inc., 2014
8"	244OF	Flanged	Emergency Vent	8 or 16	503,517	Colorado Engineering Experiment Station Inc., 2014
8"	244OM	Male Threads	Emergency Vent	8 or 16	503,517	Colorado Engineering Experiment Station Inc., 2014
8"	245M	Male Threads	Emergency Vent	8	527,441	Colorado Engineering Experiment Station Inc., 2018
8"	245	Female Threads	Emergency Vent	8	527,441	Colorado Engineering Experiment Station Inc., 2018
8"	245F	Flanged	Emergency Vent	8	527,441	Colorado Engineering Experiment Station Inc., 2018
10"	244OF	Flanged	Emergency Vent	8 or 16	890,275	Colorado Engineering Experiment Station Inc., 2014
10"	245F	Flanged	Emergency Vent	8	972,110	Colorado Engineering Experiment Station Inc., 2018



244 Series Emergency Vent

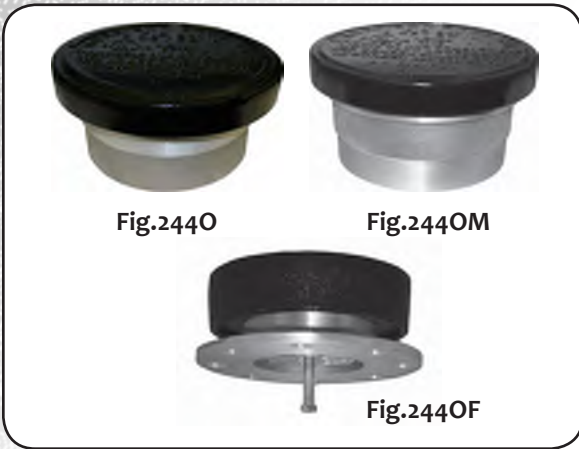

Fig.244O

Fig.244OM

Fig.244OF

NOTE

Use EVR models to comply with pressure decay test. Contact factory for assistance.

UL Listed emergency vent (pressure relief only) used on aboveground storage tanks, as a code requirement, to help prevent the tank from becoming over-pressurized and possibly rupturing if ever exposed to fire. The vent must be used in conjunction with a "normal vent." Correct application of this vent requires proper vent size and selection for the tank system in order to meet the specific venting capacity.

Code Compliance

When properly sized for the tank, this vent will conform to the requirements of the International Fire Code; National Fire Code of Canada; National Fire Protection Agency - NFPA 1, 30, 30A, 31, 37, 110; Petroleum Equipment Institute - PEI RP200, PEI RP800; Underwriters Laboratories Inc. UL-142, UL-2085, UL- 2244; Underwriters Laboratories of Canada CAN/ULC S601, CAN/ULC S602, CAN/ULC S652, OSHA 1910.106

Approvals

California Air Resource Board (CARB) Phase 1 Enhanced Vapor Recovery (EVR) AST Certified Products (VR-402-B), Underwriters Laboratories Inc. UL-2583, Morrison venting guide

Construction Details

2" Vent

Body... Aluminum, iron, or brass

Cover... Aluminum or brass

O-Ring... FKM

Screen... 4 mesh stainless steel (optional)

Center Pin... Zinc-plated steel

3", 4", 5", 6", 8", 10" Vents

Body... Aluminum

Cover... Power coated cast iron

O-Ring... FKM-A, standard models

O-Ring... FKM-B, Model numbers ending in AVE or AVEVR

Screen... 3 mesh stainless steel (3",4",5" and 6") (optional)

NOTE

Emergency vent should be set higher than the normal vent so the normal vent operates first.

WARNINGS: The 244 emergency vent is for "emergency pressure relief only" and must be used in conjunction with a "normal vent" or pressure vacuum vent such as a Morrison Fig. 354,748, 948A, 749 or 922. The 244 emergency vent must be properly sized and selected for each specific tank application in order to meet the proper "venting capacity" requirements. See the Morrison Vent Guide for further instructions.

WARNING: DO NOT FILL OR UNLOAD FUEL FROM A STORAGE TANK UNLESS IT IS CERTAIN THAT THE TANK VENTS WILL OPERATE PROPERLY. Morrison tank vents are designed only for use on shop fabricated atmospheric tanks which have been built and tested in accordance with UL 142, NFPA 30 & 30A, and API 650 and in accordance with all applicable local, state and federal laws. In normal operation, dust and debris can accumulate in vent openings and block air passages. Certain atmospheric conditions such as a sudden drop in temperature, below freezing temperatures, and freezing rain can cause moisture to enter the vent and freeze which can restrict internal movement of vent mechanisms and block air passages. All storage tank vent air passages must be completely free of restriction and all vent mechanisms must have free movement in order to insure proper operation. Any restriction of airflow can cause excessive pressure or vacuum to build up in the storage tank, which can result in structural damage to the tank, fuel spillage, property damage, fire, injury, and death. Monthly inspection, and immediate inspection during freezing conditions, by someone familiar with the proper operation of storage tank vents, is required to insure venting devices are functioning properly before filling or unloading a tank. Normal vents such as pressure vacuum and updraft vents for aboveground storage tanks should be sized according to NFPA 30 (2008) 21.4.3

Item Number	Size	Opening Pressure Setting (oz/in ²)	Weight (lbs)	Venting Capacity (*Est. SCFH @ 2.5 PSI)	Mounting Connection	
244O	3"	8.0	7.00	60,994	Female NPT	
		16.0	11.00	60,994	Female NPT	
	4"	8.0	10.00	131,700	Female NPT	
		16.0*	18.00	131,700	Female NPT	
	5"	8.0	14.00	190,087	Female NPT	
		16.0*	27.00	190,087	Female NPT	
	6"	8.0*	19.00	299,684	Female NPT	
		16.0*	36.00	299,684	Female NPT	
	8"	8.0*	33.00	503,517	Female NPT	
		16.0*	62.00	503,517	Female NPT	
	244OF	4"	8.0	11.00	131,700	Flanged
			16.0	20.00	131,700	Flanged
6"		8.0	21.00	299,684	Flanged	
		16.0	38.00	299,684	Flanged	
8"		8.0	33.00	503,517	Flanged	
		16.0	67.00	503,517	Flanged	
10"		2.5	25.00	881,670	Flanged	
		8.0	57.00	890,275	Flanged	
		16.0	103.00	890,275	Flanged	
244OM		2"	8.0	1.0	31,917	Male NPT
	16.0*		0.4	31,917	Male NPT	
	3"	8.0	7.00	60,994	Male NPT	
		16.0*	11.0	60,994	Male NPT	
	4"	8.0	10.00	131,700	Male NPT	
		16.0*	19.00	131,700	Male NPT	
	5"	8.0	15.00	190,087	Male NPT	
		16.0*	28.00	190,087	Male NPT	
	6"	8.0*	20.00	299,684	Male NPT	
		16.0*	37.00	299,684	Male NPT	
	8"	8.0*	34.00	503,517	Male NPT	
		16.0*	63.00	503,517	Male NPT	
244OMI	3"	8.0	8.00	60,994	Male NPT	

* Indicates EVR models available.



UL
2583

245 Series Lightweight Emergency Vent

This lightweight, spring-loaded emergency vent (pressure relief only) is used on aboveground storage tanks, as a code requirement, to help prevent the tank from becoming over-pressurized and possibly rupturing if ever exposed to fire. This vent must be used in conjunction with a “normal vent.” Correct application of this vent requires proper vent size and selection for the tank system in order to meet the specific venting capacity.

Construction Details

Body... Aluminum
Cover... Aluminum
Seat... FKM
Bolt... Zinc plated steel

Code Compliance

NFPA 1, 30, 30A, 31, 37, 110; PEI RP200, PEI RP800; UL 142, UL 142A, UL 2085, UL 2244; CAN/ULC S601, CAN/ULC S602, CAN/ULC S652

Approvals

Underwriters Laboratories Inc. UL-2583

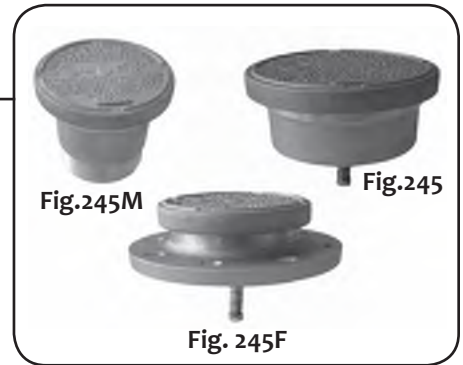

NOTE

Emergency vent should be set higher than the normal vent so the normal vent operates first.

Item Number	Size	Opening Pressure Setting (oz/in ²)	Weight (lbs)	Venting Capacity (*Est. SCFH @ 2.5 PSI)	Mounting Connection
245	3"	8.0	2.80	67,162	Female NPT
	4"	8.0	3.30	129,369	Female NPT
	6"	8.0	5.50	331,750	Female NPT
	8"	8.0	9.20	527,441	Female NPT
245M	2"	8.0	0.50	31,917	Male NPT
	3"	8.0	2.50	67,162	Male NPT
	4"	8.0	4.50	129,369	Male NPT
	6"	8.0	6.20	331,750	Male NPT
	8"	8.0	10.10	527,441	Male NPT
245F	4"	8.0	6.00	129,369	Flanged
	6"	8.0	9.10	331,750	Flanged
	8"	8.0	14.50	527,441	Flanged
	10"	8.0	20.00	972,110	Flanged

WARNING: DO NOT FILL OR UNLOAD FUEL FROM A STORAGE TANK UNLESS IT IS CERTAIN THAT THE TANK VENTS WILL OPERATE PROPERLY. Morrison tank vents are designed only for use on shop fabricated atmospheric tanks which have been built and tested in accordance with UL 142, NFPA 30 & 30A, and API 650 and in accordance with all applicable local, state and federal laws. In normal operation, dust and debris can accumulate in vent openings and block air passages. Certain atmospheric conditions such as a sudden drop in temperature, below freezing temperatures, and freezing rain can cause moisture to enter the vent and freeze which can restrict internal movement of vent mechanisms and block air passages. All storage tank vent air passages must be completely free of restriction and all vent mechanisms must have free movement in order to insure proper operation. Any restriction of airflow can cause excessive pressure or vacuum to build up in the storage tank, which can result in structural damage to the tank, fuel spillage, property damage, fire, injury, and death. Monthly inspection, and immediate inspection during freezing conditions, by someone familiar with the proper operation of storage tank vents, is required to insure venting devices are functioning properly before filling or unloading a tank. Normal vents such as pressure vacuum and updraft vents for aboveground storage tanks should be sized according to NFPA 30 (2008) 21.4.3



Fig. 244A

244A Flanged Adaptor

Flange adaptors are welded to tank top openings in aboveground storage tanks creating a flanged emergency vent connection.

Construction Details

Carbon steel welded rim and skirt.

Size	Weight (lbs)
4" (eight 3/4" holes on 7 1/2" B.C.)	10.0
6" (eight 7/8" holes on 9 1/2" B.C.)	12.0
8" (eight 7/8" holes on 11 3/4" B.C.)	19.0
10" (twelve 1" holes on 14 1/4" B.C.)	20.0

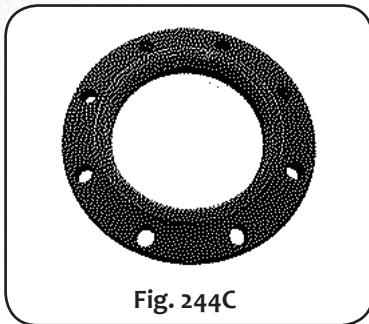

Fig. 244C

244C Companion Flange

Female threads designed to convert a male threaded pipe nipple to a 150# raised face flange connection.

Construction Details

Cast iron with female NPT "center port" I.D.

Size	Weight (lbs)
8" (eight 7/8" holes on 11 3/4" B.C. w/8" NPT I.D.)	27.0
10" (twelve 1" holes on 14 1/4" B.C. w/10" NPT I.D.)	36.0

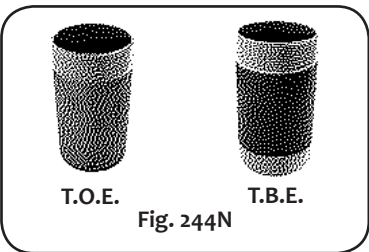

Fig. 244N

244N Pipe Nipple

Steel pipe with male threads on one end (T.O.E) or with male threads on both ends (T.B.E).

Construction Details

Carbon steel —NPT

Size	Weight (lbs)
4" x 8"	7.00
6" x 8"	13.0
8" x 8"	20.0
8" x 12"	28.0

*Other lengths available.



948A Series Pressure/Vacuum Vent

The 948A pressure vacuum vent is designed for installation on top of the vent pipe of an aboveground or underground storage tank. The poppets seal vapors in the tank when pressure is equalized. The vent allows the tank to “breathe” during filling and discharging operations.

Features

- UL Listing for compatibility with gasoline, ethanol (to E-85), biodiesel (to B-20)
- Conserves vapors
- Durable construction
- Easily replaceable seals extend life expectancy
- Outlasts other brands by many years of service
- Operating temperature -40° F to 130° F
- Full 2-inch orifice for maximum flow rate

Construction Details

Body... Anodized aluminum
 Seals... FKM
 Screens... Stainless steel
 Handle... Stainless steel
 Rainguard... Aluminum

Leak Rates and Settings

- Pressure leak rate: Less than 0.05 SCFH @ 2.00" WC
- Vacuum leak rate: Less than 0.21 SCFH @ 4.00: WC
- Opening pressure: 2.5" to 6.0" WC
- Opening vacuum: 6.0" to 10.0" WC
-

Estimated Flow Rates

- 36,720 SCFH @ 2.5 PSI pressure
- 8,000 SCFH @ -0.5 PSI vacuum

Certifications and Listings

UL 2583 Listed; 948A Pressure Vacuum Vents meet the requirements of EPA 40 CFR part 63 for Gasoline Dispensing Facilities; Missouri Air Conservation Commission Approved for Rule 10 CSR 10.2.260 and 10.5.220

Size	Pressure Setting (oz/in ²)	Vacuum Setting (oz/in ²)	Weight (lbs)	Venting Capacity (SCFH) (@2.5 PSI)
2"	2.5" to 6" W.C.	6" to 10" W.C.	6.75	36,720



Fig. 948A

NOTE

Normal vents such as pressure vacuum and updraft vents for aboveground storage tanks should be sized according to NFPA 30 (2015) 21.4.3.3

WARNING: DO NOT FILL OR UNLOAD FUEL FROM A STORAGE TANK UNLESS IT IS CERTAIN THAT THE TANK VENTS WILL OPERATE PROPERLY. Morrison tank vents are designed only for use on shop fabricated atmospheric tanks which have been built and tested in accordance with UL 142, NFPA 30 & 30A, and API 650 and in accordance with all applicable local, state, and federal laws. In normal operation, dust and debris can accumulate in vent openings and block air passages. Certain atmospheric conditions such as a sudden drop in temperature, below freezing temperatures, and freezing rain can cause moisture to enter the vent and freeze which can restrict internal movement of vent mechanisms and block air passages. All storage tank vent air passages must be completely free of restriction and all vent mechanisms must have free movement in order to insure proper operation. Any restriction of airflow can cause excessive pressure or vacuum to build up in the storage tank, which can result in structural damage to the tank, fuel spillage, property damage, fire, injury, and death. Monthly inspection, and immediate inspection during freezing conditions, by someone familiar with the proper operation of storage tank vents, is required to insure venting devices are functioning properly before filling or unloading a tank.



Fig. 748A

NOTE

Normal vents such as pressure vacuum and updraft vents for aboveground storage tanks should be sized according to NFPA 30 (2015) 21.4.3.3

748A Series Pressure/Vacuum Vent

Pressure vacuum vent designed for installation on top of the vent pipe of an aboveground or underground storage tank. Poppets seal vapors in the tank when pressure is equalized. The vent allows the tank to "breathe" during filling and dispensing operations. This vent must be used in conjunction with an emergency vent. It is recommended that the opening pressure setting is set below that of the emergency vent so the normal vent operates first. Settings are approximate.

Features

- Vents outward and upward in compliance with NFPA 30
- Tri-polar mounting screws for mounting exhaust hood in any of three positions
- Optional dryer connections accommodate the installation of desiccant dryers on vacuum connection
- Optional pressure discharge hood facilitates piping pressure relief to desired discharge point

Construction Details

Body and hood... Aluminum
 Seats... Passivated aluminum
 Poppets... Brass
 Screens... Stainless steel

Size	Pressure Setting (oz/in ²)	Vacuum Setting (oz/in ²)	Weight (lbs)	Venting Capacity (SCFH) (@2.5 PSI)
2"	2.0	1.0	6.75	20,200
2"	4.0	1.0	7.50	20,200
2"	6.0	1.0	8.25	20,200
2"	8.0	1.0	9.25	20,000
2"	12.0	1.0	10.50	18,600
2"	16.0	1.0	11.00	18,600



Fig. 748ALT

748ALT Series Pressure/Vacuum Vent

Pressure vacuum vent valve used with aqua-ammonia and ag-chemical products allowing tank to "breathe" during filling and dispensing operations. Poppets seal vapors in the tank when pressure is equalized. Settings are approximate.

Construction Details

Size... 2" NPT
 Body and Cap... Aluminum
 Poppets... PTFE coated Aluminum
 Screens... Stainless steel
 Option (must specify)... Male NPT connection for dryer application
 Option... Pressure discharge NPT hood

Size	Pressure Setting (oz/in ²)	Vacuum Setting (oz/in ²)	Weight (lbs)	Venting Capacity (SCFH) (@2.5 PSI)
2"	8.0	1.0	5.50	20,000
2"	16.0	1.0	5.50	18,000
2"	32.0	1.0	5.50	N/A

WARNING: DO NOT FILL OR UNLOAD FUEL FROM A STORAGE TANK UNLESS IT IS CERTAIN THAT THE TANK VENTS WILL OPERATE PROPERLY. Morrison tank vents are designed only for use on shop fabricated atmospheric tanks which have been built and tested in accordance with UL 142, NFPA 30 & 30A, and API 650 and in accordance with all applicable local, state, and federal laws. In normal operation, dust and debris can accumulate in vent openings and block air passages. Certain atmospheric conditions such as a sudden drop in temperature, below freezing temperatures, and freezing rain can cause moisture to enter the vent and freeze which can restrict internal movement of vent mechanisms and block air passages. All storage tank vent air passages must be completely free of restriction and all vent mechanisms must have free movement in order to insure proper operation. Any restriction of airflow can cause excessive pressure or vacuum to build up in the storage tank, which can result in structural damage to the tank, fuel spillage, property damage, fire, injury, and death. Monthly inspection, and immediate inspection during freezing conditions, by someone familiar with the proper operation of storage tank vents, is required to insure venting devices are functioning properly before filling or unloading a tank.



748A Series 3" Pressure/Vacuum Vent

Pressure vacuum vent designed for installation on top of the vent pipe of an aboveground storage tank. Poppets seal vapors in the tank when pressure is equalized. The vent allows the tank to “breathe” during filling and dispensing operations. This vent must be used in conjunction with an emergency vent. It is recommended that the opening pressure setting is set below that of the emergency vent so the normal vent operates first. Settings are approximate.

Features

- Vents outward and upward in compliance with NFPA 30
- Tri-polar mounting screws for mounting exhaust hood in any of three positions
- Optional dryer connections accommodate the installation of desiccant dryers on vacuum connection

Construction Details

Body and hood... Aluminum

Poppets... Brass

Seats... Aluminum

Screens... Stainless steel



Fig. 748A

Size	Pressure Setting (oz/in ²)	Vacuum Setting (oz/in ²)	Weight (lbs)	Venting Capacity (SCFH) (@2.5 PSI)
3"	2.0	1.0	9.75	43,000
3"	4.0	1.0	11.15	43,000
3"	6.0	1.0	12.15	43,000
3"	8.0	1.0	13.10	43,000
3"	12.0	1.0	15.30	40,000
3"	16.0	1.0	17.75	40,000

NOTE

Normal vents such as pressure vacuum and updraft vents for aboveground storage tanks should be sized according to NFPA 30 (2015) 21.4.3.3

WARNING: DO NOT FILL OR UNLOAD FUEL FROM A STORAGE TANK UNLESS IT IS CERTAIN THAT THE TANK VENTS WILL OPERATE PROPERLY. Morrison tank vents are designed only for use on shop fabricated atmospheric tanks which have been built and tested in accordance with UL 142, NFPA 30 & 30A, and API 650 and in accordance with all applicable local, state, and federal laws. In normal operation, dust and debris can accumulate in vent openings and block air passages. Certain atmospheric conditions such as a sudden drop in temperature, below freezing temperatures, and freezing rain can cause moisture to enter the vent and freeze which can restrict internal movement of vent mechanisms and block air passages. All storage tank vent air passages must be completely free of restriction and all vent mechanisms must have free movement in order to insure proper operation. Any restriction of airflow can cause excessive pressure or vacuum to build up in the storage tank, which can result in structural damage to the tank, fuel spillage, property damage, fire, injury, and death. Monthly inspection, and immediate inspection during freezing conditions, by someone familiar with the proper operation of storage tank vents, is required to insure venting devices are functioning properly before filling or unloading a tank.



Fig. 749

749 Series Pressure/Vacuum Vent

Pressure vacuum vents are installed on the top of underground and low volume aboveground storage tank vent pipes. Vent allows tank to “breathe” during filling and discharging operations. Pressure and vacuum poppets seal vapors in tank when pressure is equalized. Settings are approximate.

Features

- Screen protects the tank from debris and insects
- Integrated internal drain port channels water away from the tank
- Vent vapors up and outward per NFPA 30
- Conserves fuel
- Certified SCFH ratings

Construction Details

Body and hood... Anodized aluminum
 Pressure poppet... Anodized aluminum
 Vacuum poppet... Brass
 Body seal... Buna-N
 Screen... 40 mesh brass
 Springs... Stainless steel
 Set screws... Zinc-plated steel

Certifications & Listings

CARB 95-14 (749CRB0500 model)
 CARB 95-15 (749CRB0600 model)
 CARB 96-19 (749CRBS0600 model)
 749CRB Pressure Vacuum Vents (models 749CRB1500 AV, 749CRB1600 AV, and 749CRBS1600 AV), meet the requirements of EPA 40 CFR part 63 for Gasoline Dispensing Facilities

WARNING
 Fig. 749 P/V vent must only be used in conjunction with motor fueling and/or low capacity flow. Fluid handling in lines larger than that used for retail service stations can cause tank to rupture or implode.

Item Number	Size	Pressure Setting (oz/in ²)	Vacuum Setting (oz/in ²)	Weight (lbs)	Venting Capacity (SCFH) (@ 2.5 PSI)
749	2"	8.0	0.5	1.00	8,500
749	2"	12.0	0.5	1.00	8,500
749	3"	8.0	0.5	1.55	8,500
749	3"	12.0	0.5	1.55	8,500
749S	2"	8.0	0.5	1.00	8,500
749S	2"	12.0	0.5	1.00	8,500
749S	3"	8.0	0.5	1.55	8,500
749S	3"	12.0	0.5	1.55	8,500
749CRB	2"	3"W.C.	8" W.C.	1.45	11,000
749CRB	3"	3"W.C.	8" W.C.	1.95	11,000
749CRBS	2"	8 oz	5 oz	1.45	11,000
749CRBS	3"	8 oz	5 oz	1.95	11,000
749BSP	2"	8.0	0.5	1.0	8,500
749BSP	2"	12.0	0.5	1.00	8,500

WARNING: DO NOT FILL OR UNLOAD FUEL FROM A STORAGE TANK UNLESS IT IS CERTAIN THAT THE TANK VENTS WILL OPERATE PROPERLY. Morrison tank vents are designed only for use on shop fabricated atmospheric tanks which have been built and tested in accordance with UL 142, NFPA 30 & 30A, and API 650 and in accordance with all applicable local, state and federal laws. In normal operation, dust and debris can accumulate in vent openings and block air passages. Certain atmospheric conditions such as a sudden drop in temperature, below freezing temperatures, and freezing rain can cause moisture to enter the vent and freeze which can restrict internal movement of vent mechanisms and block air passages. All storage tank vent air passages must be completely free of restriction and all vent mechanisms must have free movement in order to insure proper operation. Any restriction of airflow can cause excessive pressure or vacuum to build up in the storage tank, which can result in structural damage to the tank, fuel spillage, property damage, fire, injury, and death. Monthly inspection, and immediate inspection during freezing conditions, by someone familiar with the proper operation of storage tank vents, is required to insure venting devices are functioning properly before filling or unloading a tank. Normal vents such as pressure vacuum and updraft vents for aboveground storage tanks should be sized according to NFPA 30 (2008) 21.4.3.



922 Combination Vent/Overfill Alarm

The audible alarm whistles when the liquid level in the aboveground storage tank reaches the preset level. The pressure vacuum vent allows the tank to “breathe” during filling and dispensing operations.

2" Pressure relief setting	6 oz/in ² or 8 oz/in ²
2" Vacuum relief setting	1 oz/in ²
2" Venting capacity (SCFH)	30,120 or 30,300
2" Weight	7.50 lbs

3" Pressure relief setting	6 oz/in ² or 8 oz/in ²
3" Vacuum relief setting	1 oz/in ²
3" Venting capacity (SCFH)	43,020 or 44,160
3" Weight	5.25 lbs



Fig. 922

Features

- Functions as both a pressure vacuum vent and audible alarm while utilizing a single 2" or 3" tank opening. Installs on the top of the vent pipe, generally 12 feet above grade
- 105 to 120 decibel whistle alarm (measured at a distance of 1 foot with a fill rate of 90 GPM)
- Fully mechanical alarm does not require electricity or batteries
- The alarm level can be set to activate at any liquid level by adjusting the cable length to the float device
- Minimum fill rate of 20 GPM required for alarm to operate

NOTE

922 not for use on vapor recovery systems.

Construction Details

Body... Anodized aluminum
 Screens... Stainless steel
 Rainguard... Aluminum
 Seals... FKM
 Ball... PTFE
 Float... Stainless steel

WARNING

All emergency vents, fill connections, tank openings, and piping connections must be airtight. Alarm/vent airway must be free of any obstruction such as dirt or ice when filling or unloading tank. Emergency vent should be set at least 2 oz. higher than combination vent.

Certifications & Listings

Florida DEP EQ-227

Item Number	Size	Pressure Setting (oz/in ²)	Venting Capacity (SCFH) (@ 2.5 PSI)	dB Rating*	Width	Height	Weight (lbs)
922	2"	8.0	30,300	120	6.8	9.0	8.50
922	2"	6.0	30,120	120	6.8	9.0	8.50
922	3"	8.0	43,020	110	6.8	9.0	6.30
922	3"	6.0	44,160	105	6.8	9.0	6.30

WARNING: DO NOT FILL OR UNLOAD FUEL FROM A STORAGE TANK UNLESS IT IS CERTAIN THAT THE TANK VENTS WILL OPERATE PROPERLY. Morrison tank vents are designed only for use on shop fabricated atmospheric tanks which have been built and tested in accordance with UL 142, NFPA 30 & 30A, and API 650 and in accordance with all applicable local, state and federal laws. In normal operation, dust and debris can accumulate in vent openings and block air passages. Certain atmospheric conditions such as a sudden drop in temperature, below freezing temperatures, and freezing rain can cause moisture to enter the vent and freeze which can restrict internal movement of vent mechanisms and block air passages. All storage tank vent air passages must be completely free of restriction and all vent mechanisms must have free movement in order to insure proper operation. Any restriction of airflow can cause excessive pressure or vacuum to build up in the storage tank, which can result in structural damage to the tank, fuel spillage, property damage, fire, injury, and death. Monthly inspection, and immediate inspection during freezing conditions, by someone familiar with the proper operation of storage tank vents, is required to insure venting devices are functioning properly before filling or unloading a tank. Normal vents such as pressure vacuum and updraft vents for aboveground storage tanks should be sized according to NFPA 30 (2008) 21.4.3.



Fig. 351S with 748A

WARNINGS: Do not use with acetylene, carbon disulfide, etheleneoxide or hydrogen gases. For use with normal hydrocarbon flames such as gasoline in air. Routine inspection is required to ensure airways are clear and free of debris. Blocked airways can cause structural deformation of the tank.

351S & 748A Flame Arrester

Flame arresters provide a positive barrier that deters flames from passing through the pressure vacuum vent line into a storage tank's vapor space.

Features

- Directs vapors outward and upward in accordance with NFPA 30
- Protects the vent line from debris and insects
- Tri-polar mounting screws for mounting exhaust hood in any of three positions
- Optional pressure discharge hood facilitates piping pressure relief to desired discharge point

Construction Details

351S

Body and cover... Cast iron
 Arrester plates... Stainless steel
 Arrester grid housing... Brass

748A

Body and hood... Aluminum
 Poppets... Brass
 Screens... 30 mesh stainless steel

Size	Pressure Setting (oz/in ²)	Vacuum Setting (oz/in ²)	Weight (lbs)	Venting Capacity (SCFH) (@2.5 PSI)
2"	2.0	1.0	42.00	15,500
2"	4.0	1.0	42.50	15,500
2"	6.0	1.0	42.75	15,500
2"	8.0	1.0	43.50	15,500
2"	12.0	1.0	44.50	13,000
2"	16.0	1.0	45.75	13,000



Fig. 352

352 End-of-Line, Open Air Deflagration Flame Arrester

End-of-Line flame arresters are designed to be installed at the end connection of a tank vent line. The flame arrester provides a protection barrier that deters a flame generated from a source outside of the tank from flashing through the vent into the vapor space of the tank.

Features

- 304 stainless arrester plates provide long term corrosion resistance and durability
- Easy access for visual inspection and periodic maintenance
- Full 2" and 3" NPT vent line air flow capacity
- Water-resistant cover sheds water away from the vent line

Construction Details

Base.... 356 tempered aluminum
 Cover... Aluminum
 Arrester plates... 304 stainless steel
 Threaded hardware... 18-8 stainless steel

Size	Weight (lbs)	Venting Capacity (SCFH) (@2.5 PSI)
2"	7.87	57,000
3"	15.60	117,000

Certifications & Listings

UL 525 Listed—Standard for Flame Arresters—Edition 8

NOTE
For petroleum storage tanks containing Group D* fluids.

*NFPA 70, the National Electrical Code, lists or defines hazardous gases, vapors, and dusts by "Groups." Consult these resources for information on Group D fluids.

WARNING: DO NOT FILL OR UNLOAD FUEL FROM A STORAGE TANK UNLESS IT IS CERTAIN THAT THE TANK VENTS WILL OPERATE PROPERLY. Morrison tank vents are designed only for use on shop fabricated atmospheric tanks which have been built and tested in accordance with UL 142, NFPA 30 & 30A, and API 650 and in accordance with all applicable local, state and federal laws. In normal operation, dust and debris can accumulate in vent openings and block air passages. Certain atmospheric conditions such as a sudden drop in temperature, below freezing temperatures, and freezing rain can cause moisture to enter the vent and freeze which can restrict internal movement of vent mechanisms and block air passages. All storage tank vent air passages must be completely free of restriction and all vent mechanisms must have free movement in order to insure proper operation. Any restriction of airflow can cause excessive pressure or vacuum to build up in the storage tank, which can result in structural damage to the tank, fuel spillage, property damage, fire, injury, and death. Monthly inspection, and immediate inspection during freezing conditions, by someone familiar with the proper operation of storage tank vents, is required to insure venting devices are functioning properly before filling or unloading a tank. Normal vents such as pressure vacuum and updraft vents for aboveground storage tanks should be sized according to NFPA 30 (2008) 21.4.3.



354 Updraft Vent

Atmospheric updraft vents are installed on the top of storage tank vent pipes on underground and aboveground fuel storage tanks.

Features

- Directs vapors outward and upward in accordance with NFPA 30
- Protects the vent line from debris and insects
- Water-resistant rain cap sheds water away from the vent line
- Slip-on design with set screws for easy installation
- Internal drain channels water penetration out through weep hole

Construction Details

Body and cap... Aluminum die cast
Screen... 40 mesh stainless steel

Certifications & Listings

CARB 89-12 (1½" and 2" 354 models)

Size (slip-on)	Weight (lbs)	Venting Capacity (SCFH) (@2.5 PSI)
1½"	0.75	27,650
2"	0.75	27,650
3"	1.50	59,000
4"	2.25	116,900



Fig. 354

NOTE
Open vents will allow unrestricted evaporation of product.

WARNING: DO NOT FILL OR UNLOAD FUEL FROM A STORAGE TANK UNLESS IT IS CERTAIN THAT THE TANK VENTS WILL OPERATE PROPERLY. Morrison tank vents are designed only for use on shop fabricated atmospheric tanks which have been built and tested in accordance with UL 142, NFPA 30 & 30A, and API 650 and in accordance with all applicable local, state and federal laws. In normal operation, dust and debris can accumulate in vent openings and block air passages. Certain atmospheric conditions such as a sudden drop in temperature, below freezing temperatures, and freezing rain can cause moisture to enter the vent and freeze which can restrict internal movement of vent mechanisms and block air passages. All storage tank vent air passages must be completely free of restriction and all vent mechanisms must have free movement in order to insure proper operation. Any restriction of airflow can cause excessive pressure or vacuum to build up in the storage tank, which can result in structural damage to the tank, fuel spillage, property damage, fire, injury, and death. Monthly inspection, and immediate inspection during freezing conditions, by someone familiar with the proper operation of storage tank vents, is required to insure venting devices are functioning properly before filling or unloading a tank. Normal vents such as pressure vacuum and updraft vents for aboveground storage tanks should be sized according to NFPA 30 (2008) 21.4.3.

155 Double Outlet Vent

The aluminum T-style vent is used primarily on fuel oil storage tanks. The T-style vent has outlet ports on either side of the inlet that have 20 mesh stainless steel screens that keep debris out of the airway.

Figure 155 is threaded and Figure 155S is a slip-on with set screw. The 155FA has a flash arrestor and the 155BSP has British Threads.

Size	Weight (lbs)
¾"	.25
1"	.50
1¼"	.50
1½"	.75
2"	1.00
3"	2.50



Fig. 155S

NOTE
Open vents will allow unrestricted evaporation of product.



Aboveground Fuel Storage - Pressure System

Horizontal cylindrical tank with top fill and remote dispenser

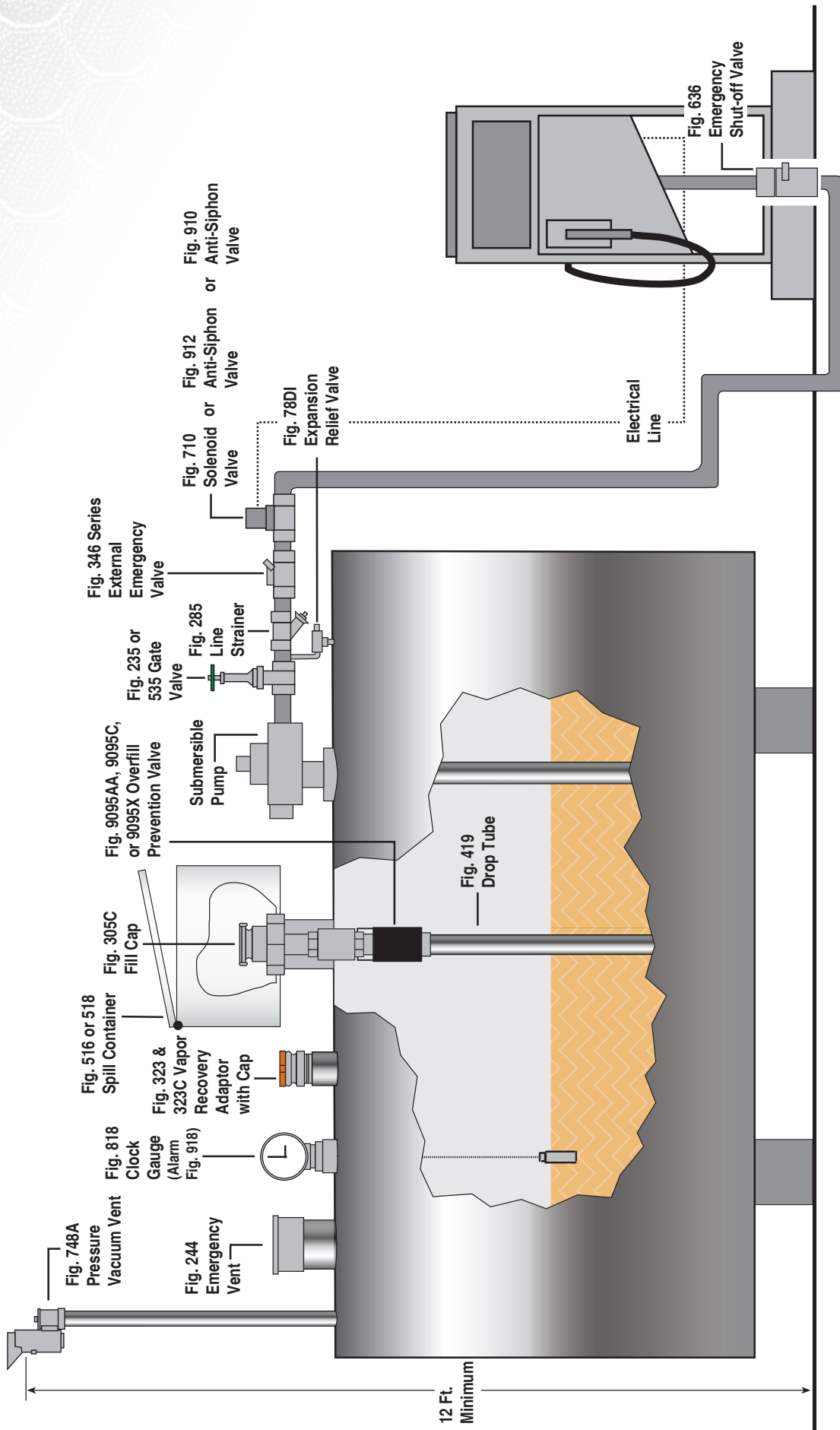



Aboveground Fuel Storage - Pressure System

Rectangular double-wall tank with remote fill and side mounted dispenser

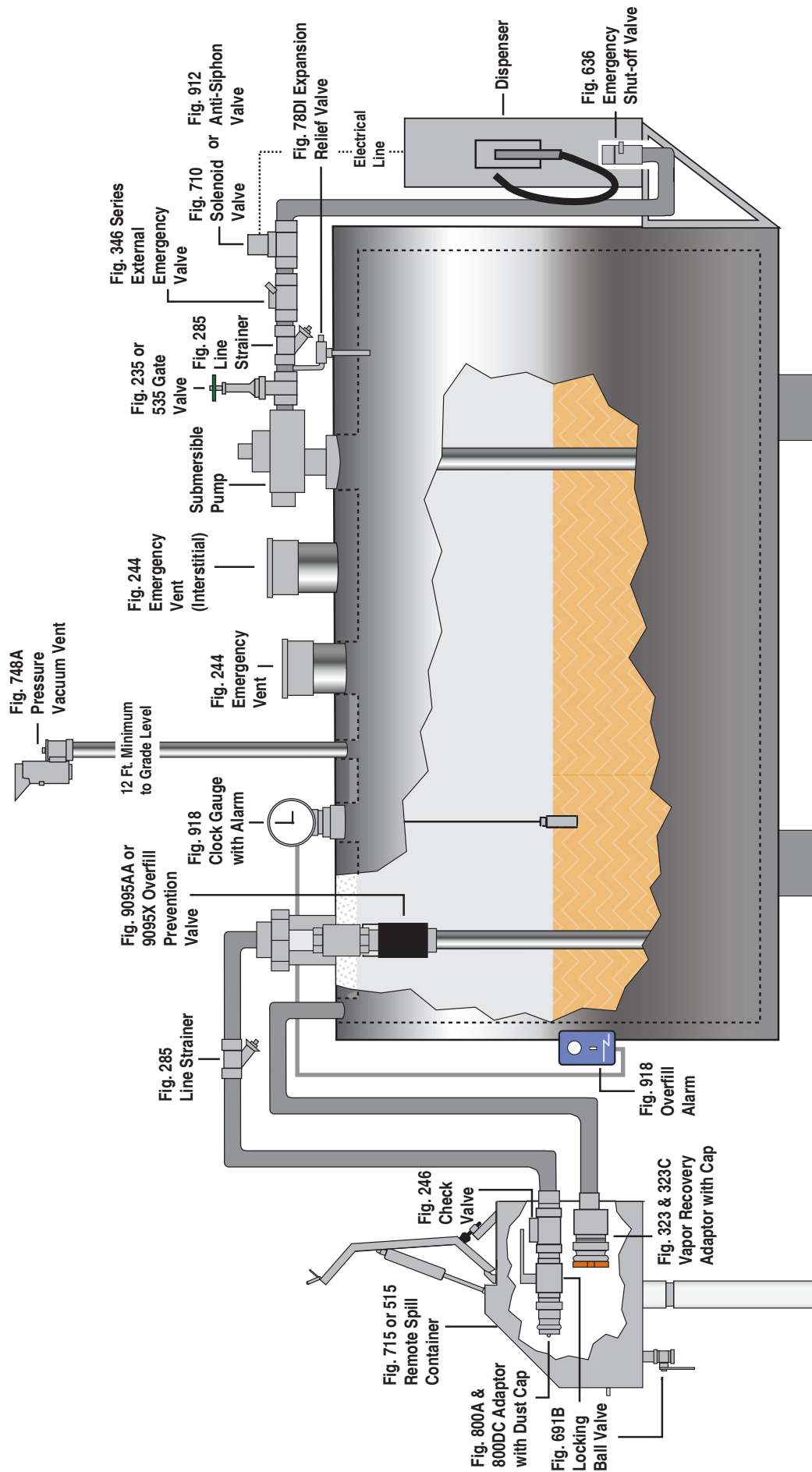



Aboveground Fuel Storage - Suction System

Horizontal cylindrical tank with top fill and top mounted pump

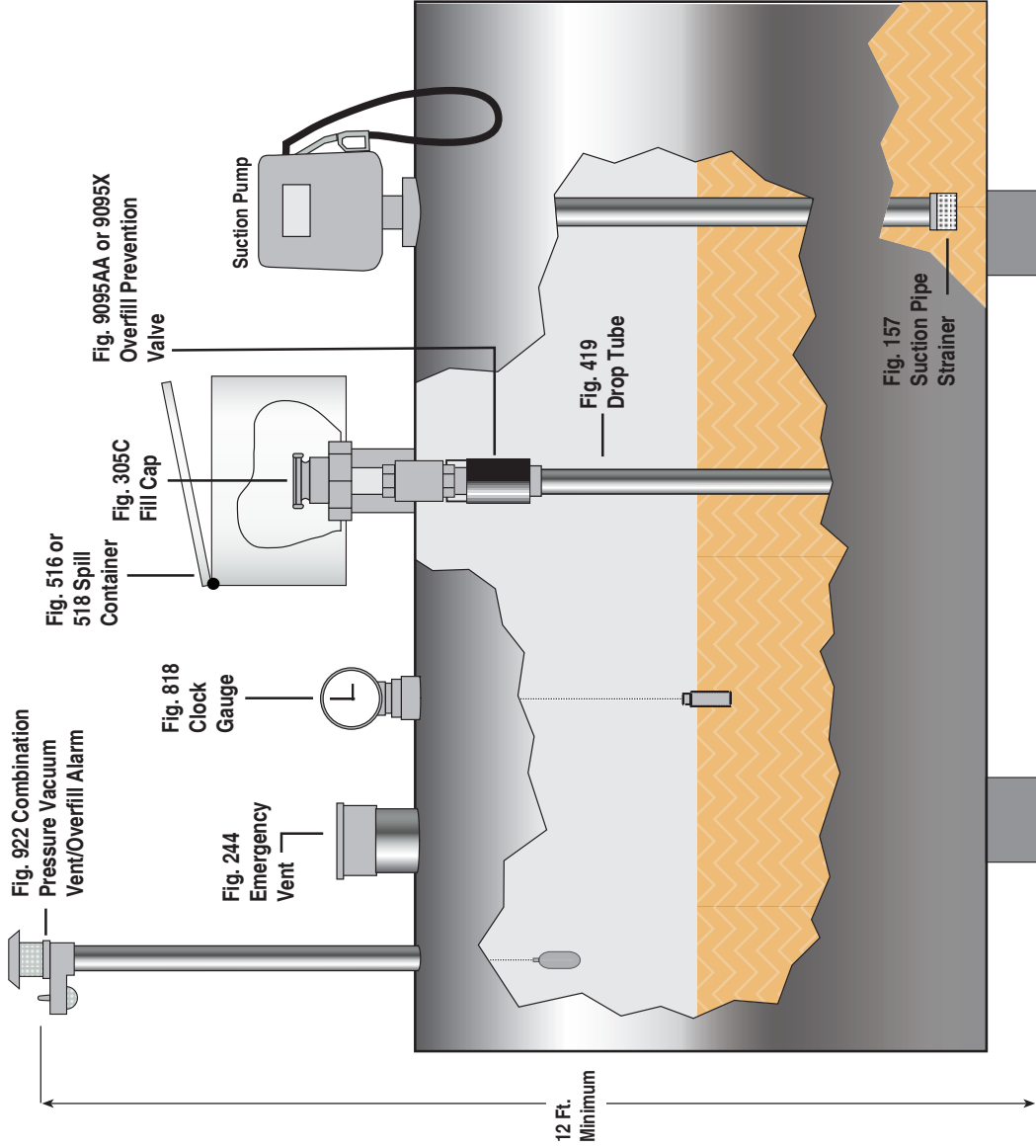



Aboveground Fuel Storage - Suction System

Rectangular double-wall tank with remote fill and remote pump

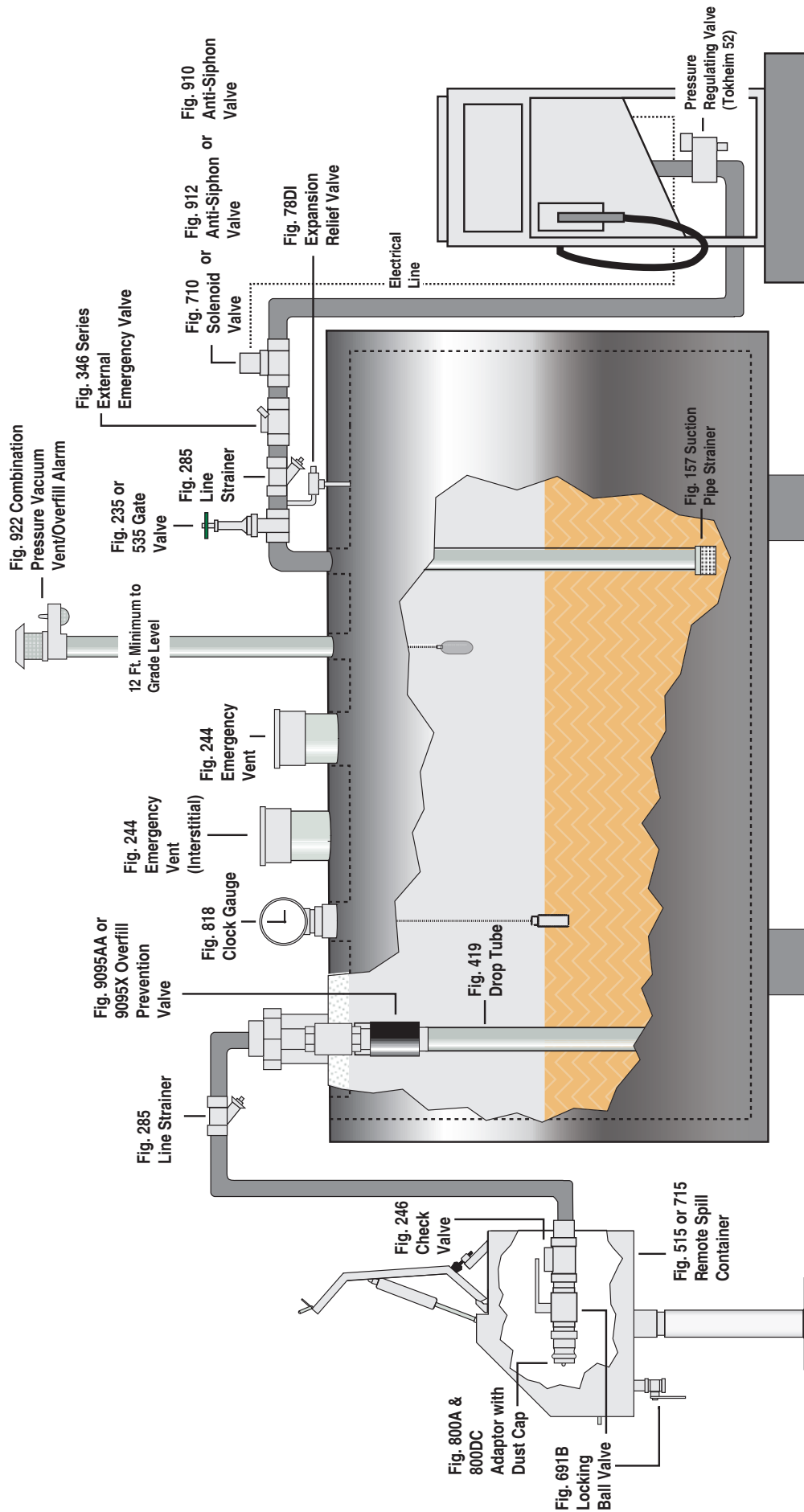



Emergency Generator or Fuel Oil Suction System

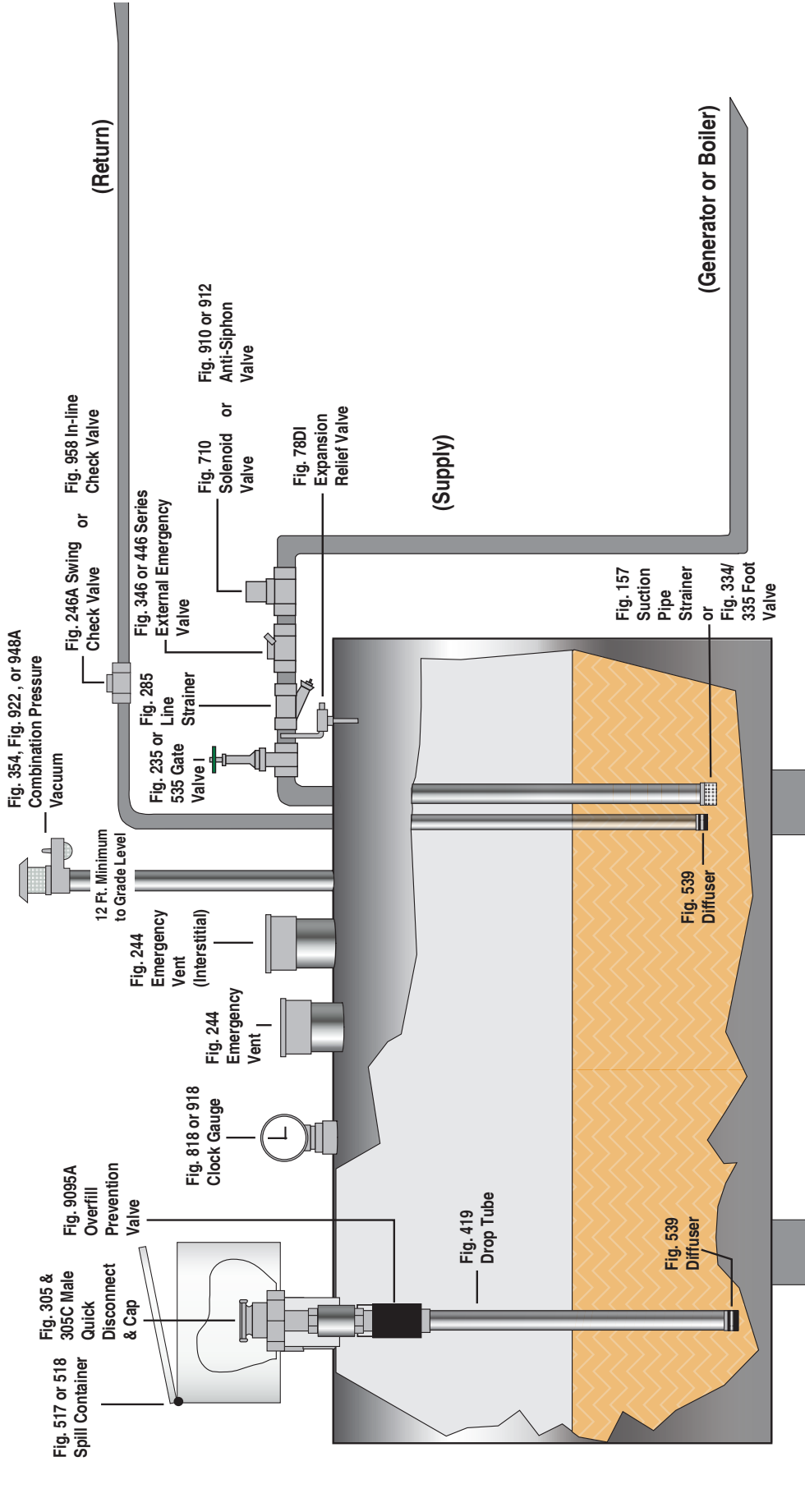



Aboveground Storage Tank - Bulk Storage

922 Combination Vent/Overfill Alarm or
351 Flame Arrester/Pressure Vacuum Vent or
748A or 948A Pressure Vacuum Vent

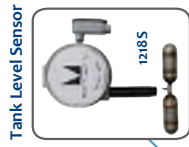

Tank Level Sensor



2440 Series Emergency Vents



715 AST Remote Fill Box or 515 Remote Spill Container

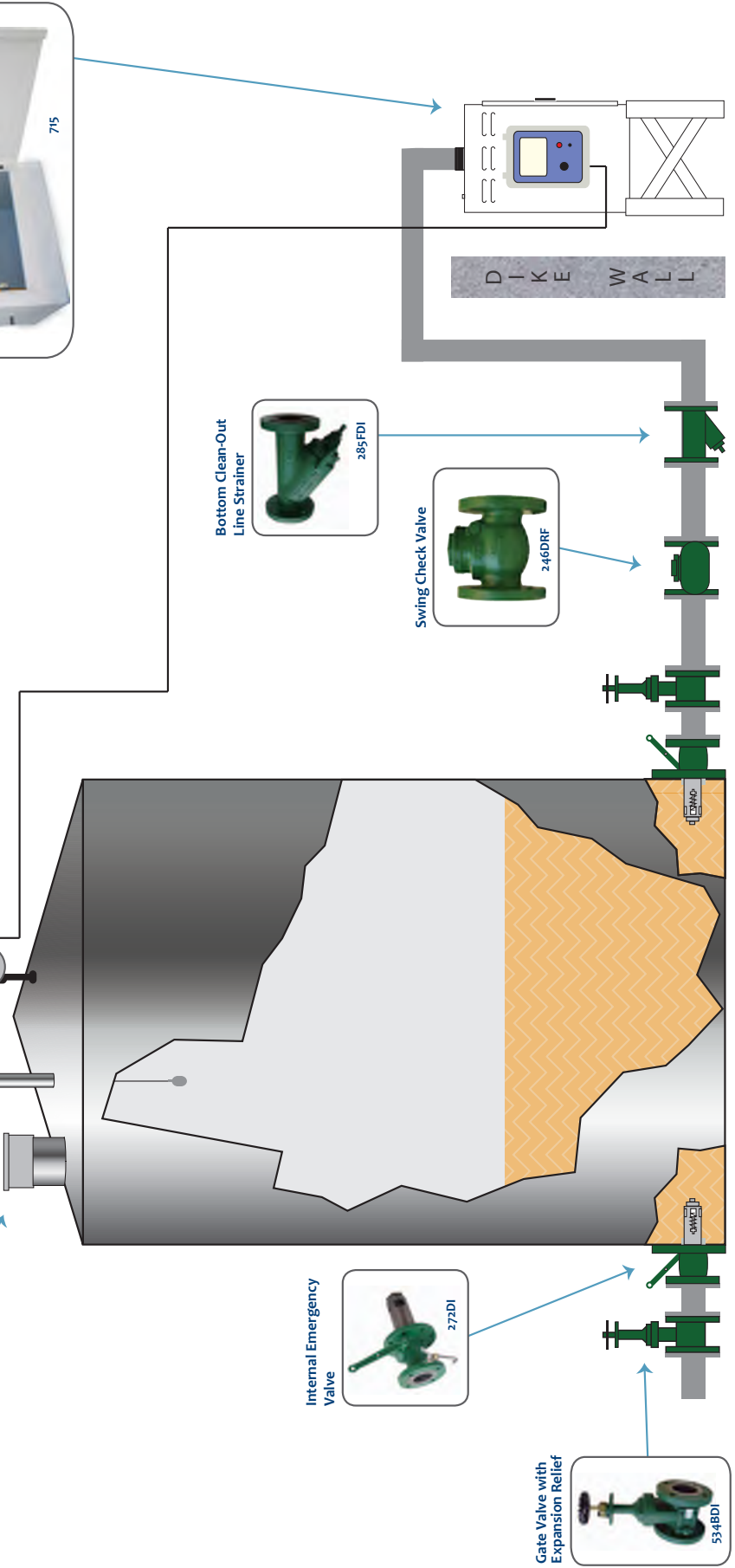

Bottom Clean-Out Line Strainer



Swing Check Valve

Internal Emergency Valve



Gate Valve with Expansion Relief







 MORRISON BROS. CO.

570 E. 7th Street, P.O. Box 238 | Dubuque, IA 52004-0238
t. 563.583.5701 | 800.553.4840 | f. 563.583.5028
custserv@morbros.com | www.morbros.com